

## Original instructions

### Pallet truck

EXH 14  
EXH 16  
EXH 18  
EXH 20  
EXH 20+  
EXH-L 16  
EXH-L 20  
EXH-SF 16C  
EXH-SF 20C



first in intralogistics



## Address of manufacturer and contact details ▷

STILL GmbH  
Berzeliusstraße 10  
22113 Hamburg, Germany  
Tel. +49 (0) 40 7339-0  
Fax: +49 (0) 40 7339-1622  
Email: [info@still.de](mailto:info@still.de)  
Website: <http://www.still.de>





## 1 Introduction

<b>Your industrial truck</b> .....	2
General .....	2
Copyright and property rights .....	2
<b>Conformity marking</b> .....	3
<b>Declaration that reflects the content of the declaration of conformity</b> .....	4
<b>Identification label</b> .....	6
<b>List of abbreviations</b> .....	7
<b>Rules for the operating company of industrial trucks</b> .....	9
<b>Spare parts list</b> .....	10
<b>Permissible use</b> .....	12
<b>Description of use and climatic conditions</b> .....	12
<b>Unauthorised use</b> .....	13
<b>Explanation of symbols used</b> .....	13
<b>Disposing of components and batteries</b> .....	13

## 2 Safety

<b>Safety regulations</b> .....	16
<b>Safety regulations for handling consumables</b> .....	17
Permissible consumables .....	17
Oils .....	17
Hydraulic fluid .....	18
Battery acid .....	18
Disposal of consumables .....	19
<b>Emissions</b> .....	20
Noise emission values .....	20
Vibration characteristics for vibrations to which the body is exposed .....	20
<b>Residual dangers, residual risks</b> .....	21
<b>Stability</b> .....	21
<b>Definition of responsible persons</b> .....	22
Operating company .....	22
Specialist .....	22
Drivers .....	22
<b>Safety tests</b> .....	24
Regular safety inspection of the truck .....	24

### 3 Overviews

<b>Overview</b> .....	26
General view of EXH 14, EXH 16, EXH 18, EXH 20 and EXH 20+ trucks .....	26
View of the technical compartment .....	27
General view of EXH-SF 16C and EXH-SF 20C trucks .....	28
<b>Operating and display devices</b> .....	29
Truck controls .....	29
Electronic key (option) .....	30
Basic display operating unit .....	32
<b>Markings</b> .....	33
Labels .....	33
Serial number .....	34

### 4 Use

<b>Technical description</b> .....	36
<b>List of checks prior to start-up</b> .....	38
<b>Starting up</b> .....	39
<b>Checks and actions prior to commissioning</b> .....	41
Checking the emergency off .....	41
Checking the brake .....	41
Checking the horn .....	42
Checking the anti-crush safety device .....	42
<b>Truck operating instructions</b> .....	44
<b>Using the Basic display-operating unit</b> .....	45
Battery indicator .....	45
Different performance modes .....	46
Other display icons .....	47
Warnings on the display .....	48
<b>Driving safety guidelines</b> .....	50
<b>Driving</b> .....	51
Defining directions .....	51
Driving .....	51
Steering .....	52
Braking .....	53
Horn .....	54
Double throw safety switch .....	55
Emergency off switch .....	55

Tortoise button . . . . .	56
Using the truck on a ramp . . . . .	56
<b>Specific features of driving with folding platform trucks . . . . .</b>	<b>59</b>
Determining the direction of travel . . . . .	59
Driving . . . . .	59
Steering . . . . .	60
Pedestrian driving . . . . .	61
Ride-on driving . . . . .	62
<b>Operating the FleetManager™ option . . . . .</b>	<b>64</b>
Description of the FleetManager option . . . . .	64
Commissioning a truck equipped with the FleetManager™ option . . . . .	65
FleetManager™ option: Colour code for the LEDs . . . . .	66
Disconnecting a truck equipped with the FleetManager™ option . . . . .	68
<b>Transporting loads . . . . .</b>	<b>70</b>
Load handling safety rules . . . . .	70
Grabbing a loading unit . . . . .	70
Transporting pallets or other containers . . . . .	71
Lifting and lowering the load arms . . . . .	72
Load handling . . . . .	72
<b>Cold store usage (optional) . . . . .</b>	<b>75</b>
<b>Before leaving the truck . . . . .</b>	<b>77</b>
<b>Handling the battery . . . . .</b>	<b>78</b>
Battery type . . . . .	78
Order picking . . . . .	78
Opening and closing the battery hood . . . . .	79
Disconnecting/connecting the battery connector . . . . .	80
Using the side socket to charge the lithium-ion battery . . . . .	81
Charging the battery using an external charger . . . . .	82
Using the on-board charger . . . . .	84
Adjusting the on-board charger . . . . .	85
General information on changing batteries . . . . .	86
Changing the vertical access battery . . . . .	86
Changing the battery on a truck equipped with a side-access battery . . . . .	88
<b>Handling the truck in an emergency . . . . .</b>	<b>92</b>
Towing and transporting the truck . . . . .	92
<b>Handling the truck in specific situations . . . . .</b>	<b>93</b>
Slinging the truck . . . . .	93
Lifting the truck . . . . .	94
Transporting the truck . . . . .	94
Transporting the machine . . . . .	95

Transporting the truck in the lift .....	95
Driving on loading bridges .....	95
<b>5 Maintenance</b>	
<b>General maintenance information</b> .....	98
General .....	98
Servicing and maintenance personnel training and qualification .....	99
Battery maintenance staff .....	99
Maintenance operations that do not require special training .....	99
Ordering spare parts and consumables .....	99
<b>Safety guidelines for maintenance</b> .....	100
Servicing and maintenance measures .....	100
Working on the electrical equipment .....	100
Safety devices .....	100
<b>Easily accessing the technical compartment</b> .....	101
<b>Technical data for inspection and maintenance</b> .....	102
<b>Recommended lubricants</b> .....	103
<b>1000-hour service plan</b> .....	104
<b>3000-hour maintenance plan</b> .....	105
<b>10,000-hour service plan</b> .....	105
<b>Chassis, bodywork and fittings</b> .....	106
Cleaning the truck .....	106
General information on battery maintenance .....	107
Checking the condition of the load arms .....	108
<b>Transmission</b> .....	109
Cleaning the traction motor cooling fins .....	109
<b>Steering and wheels</b> .....	110
Checking the condition of the wheels .....	110
Stabiliser maintenance .....	110
<b>Electrical equipment</b> .....	111
Cleaning and blowing air through the electrical components .....	111
Checking the battery acid level and electrolyte density .....	112
Checking the condition of cables, terminals and the battery connector .....	113



<b>Hydraulic systems</b> .....	114
Checking the hydraulic system for leaks .....	114
Checking the hydraulic oil level .....	114
<b>Storage and decommissioning</b> .....	116
Storage of truck .....	116
Permanent Putting Out of Commission (Destruction) .....	117

## 6 Technical specifications

<b>Datasheet for the EXH14 model</b> .....	120
<b>Datasheet for EXH16, EXH18, EXH20 and EXH20+ models</b> .....	124
<b>Eco-design requirements for electric motors and variable speed drives</b> .....	128



1

---

# Introduction

## Your industrial truck

# Your industrial truck

## General

The truck described in these operating instructions corresponds to the applicable standards and safety regulations.

If the truck is to be operated on public roads, it must conform to the existing national regulations for the country in which it is being used. The driving permit must be obtained from the appropriate office.

The truck has been fitted with state-of-the-art technology. Following these operating instructions will allow the truck to be handled safely. By complying with the specifications in these operating instructions, the functionality and the approved features of the truck will be retained.

Get to know the technology, understand it and use it safely - these operating instructions provide the necessary information and help to avoid accidents and to keep the truck ready for operation beyond the warranty period.

Therefore:

- Before commissioning the truck, read the operating instructions and follow the instructions.
- Always follow all of the safety information contained in the operating instructions and on the truck.

## Copyright and property rights

This manual - and any excerpts thereof - may not be reproduced, translated or transmitted in any form to third parties without the express written permission of the manufacturer.

## Conformity marking

The manufacturer uses the conformity marking to document the conformity of the industrial truck with the relevant directives at the time of placing on the market:

- CE: in the European Union (EU)
- UKCA: in the United Kingdom (UK)
- EAC: in the Eurasian Economic Union

The conformity marking is applied to the nameplate. A declaration of conformity is issued for the EU and UK markets.

An unauthorised structural change or addition to the industrial truck can compromise safety, thus invalidating the declaration of conformity.

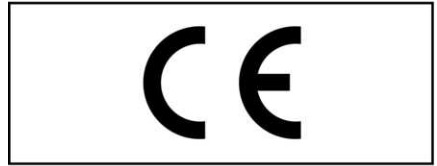

Declaration that reflects the content of the declaration of conformity

## Declaration that reflects the content of the declaration of conformity

### Declaration

STILL GmbH  
Berzeliusstraße 10  
22113 Hamburg Germany

We declare that the specified machine conforms to the most recent valid version of the directives specified below:

Industrial truck type	<b>corresponding to these operating instructions</b>
Model	<b>corresponding to these operating instructions</b>

- "Machinery Directive 2006/42/EC" <sup>1)</sup>
- "Supply of Machinery Safety Regulations 2008, 2008 No. 1597" <sup>2)</sup>

Personnel authorised to compile the technical documents:

See declaration of conformity

STILL GmbH

<sup>1)</sup> For the markets of the European Union, the EU candidate countries, the EFTA States and Switzerland.

<sup>2)</sup> For the United Kingdom market.

The declaration of conformity document is supplied with the industrial truck. The declaration shown explains the conformity with the provisions of the EC Machinery Directive and the Supply of Machinery Safety Regulation 2008, 2008 No. 1597.

An unauthorised structural change or addition to the industrial truck can compromise safety, thus invalidating the declaration of conformity.

The declaration of conformity must be carefully stored and made available to the responsible authorities if necessary. It must also be

## Declaration that reflects the content of the declaration of conformity

handed over to the new owner if the industrial truck is sold on.

## Identification label

## Identification label

## Version 1

- 1 Identification label
- 2 Manufacturer
- 3 CE symbol (this symbol means that the machine complies with European regulations for industrial trucks)
- 4 Serial number/year
- 5 Unladen weight
- 6 Battery voltage
- 7 Minimum battery weight (for a lithium-ion battery, the weight of the ballast container is included)
- 8 Maximum battery weight
- 9 Nominal capacity of the truck
- 10 Model
- 11 Nominal motor power

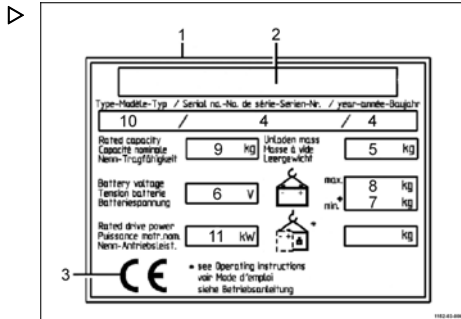

## Version 2

- 1 Identification label
- 2 Manufacturer
- 3 Model/Serial number/  
Manufacturing year
- 4 Net weight
- 5 Battery maximum weight/  
Battery minimum weight
- 6 Ballast weight
- 7 Placeholder for "data-matrix code"
- 8 Conformity marking:  
**CE marking** for EU markets, EU candidate countries, EFTA states and Switzerland  
**UKCA marking** for the UK market  
**EAC marking** for the Eurasian Economic Union market
- 9 Nominal drive power
- 10 Battery voltage
- 11 Nominal load capacity

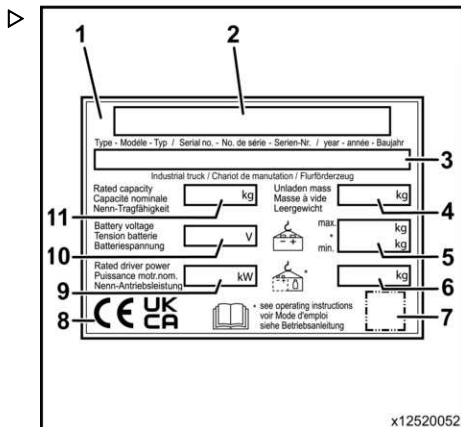



 **NOTE**

- *Several conformity markings may appear on the nameplate.*
- *The EAC marking can also be located in the immediate vicinity of the nameplate.*

## List of abbreviations

This list of abbreviations applies to all types of operating instructions. Not all of the abbreviations that are listed here will necessarily appear in these operating instructions.

Abbreviation	Meaning	Explanation
ArbSchG	Arbeitsschutzgesetz	German implementation of EU occupational health and safety directives
Betr-SichV	Betriebssicherheitsverordnung	German implementation of the EU working equipment directive
BG	Berufsgenossenschaft	German insurance company for the company and employees
BGG	Berufsgenossenschaftlicher Grundsatz	German principles and test specifications for occupational health and safety
BGR	Berufsgenossenschaftliche Regel	German rules and recommendations for occupational health and safety
DGUV	Berufsgenossenschaftliche Vorschrift	German accident prevention regulations
CE	Communauté Européenne	Confirms conformity with product-specific European directives (CE labelling)
CEE	Commission on the Rules for the Approval of the Electrical Equipment	International commission on the rules for the approval of electrical equipment
DC	Direct Current	Direct current
DFÜ	Datenfernübertragung	Remote data transfer
DIN	Deutsches Institut für Normung	German standardisation organisation
EG	European Community	
EN	European standard	
FEM	Fédération Européenne de la Manutention	European Federation of Materials Handling and Storage Equipment
F <sub>max</sub>	maximum Force	Maximum power
GAA	Gewerbeaufsichtsamt	German authority for monitoring/issuing regulations for worker protection, environmental protection, and consumer protection
GPRS	General Packet Radio Service	Transfer of data packets in wireless networks

## List of abbreviations

Abbreviation	Meaning	Explanation
ID no.	Identification number	
ISO	International Organization for Standardization	International standardisation organisation
K <sub>pA</sub>	Uncertainty of measurement of sound pressure levels	
LAN	Local Area Network	Local area network
LED	Light Emitting Diode	Light emitting diode
L <sub>p</sub>	Sound pressure level at the workplace	
L <sub>pAZ</sub>	Average continuous sound pressure level in the driver's compartment	
LSP	Load centre of gravity	Distance of the centre of gravity of the load from the front face of the fork backs
MAK	Maximum workplace concentration	Maximum permissible air concentrations of a substance at the workplace
Max.	Maximum	Highest value of an amount
Min.	Minimum	Lowest value of an amount
PIN	Personal Identification Number	Personal identification number
PPE	Personal protective equipment	
SE	Super-Elastic	Superelastic tyres (solid rubber tyres)
SIT	Snap-In Tyre	Tyres for simplified assembly, without loose rim parts
StVZO	Straßenverkehrs-Zulassungs-Ordnung	German regulations for approval of vehicles on public roads
TRGS	Technische Regel für Gefahrstoffe	Ordinance on hazardous materials applicable in the Federal Republic of Germany
UKCA	United Kingdom Conformity Assessed	Confirms conformity with the product-specific directives that apply in the United Kingdom (UKCA labelling)
VDE	Verband der Elektrotechnik Elektronik Informationstechnik e. V.	German technical/scientific association
VDI	Verein Deutscher Ingenieure	German technical/scientific association
VDMA	Verband Deutscher Maschinen- und Anlagenbau e. V.	German Mechanical Engineering Industry Association
WLAN	Wireless LAN	Wireless local area network

## Rules for the operating company of industrial trucks

In addition to these operating instructions, a code of practice containing additional information for the operating companies of industrial trucks is also available.

This guide provides information for handling industrial trucks:

- Information on how to select suitable industrial trucks for a particular area of application
- Prerequisites for the safe operation of industrial trucks
- Information on the use of industrial trucks
- Information on transport, initial commissioning and storage of industrial trucks

### Internet address and QR code



The information can be accessed at any time by pasting the address <https://m.still.de/vdma> in a web browser or by scanning the QR code.



## Spare parts list

### Spare parts list



The spare parts list can be downloaded by entering the address <https://sparepartlist.still.eu> into a web browser or by scanning the QR code displayed to the side.

When the web page is open, please type in the following password: **Spareparts24!**

On the next screen, please enter your email address and truck serial number to receive the link by email. Then download the spare parts list.





## Permissible use

### Permissible use

The truck described in these operating instructions is suitable for lifting and transporting loads.

The truck should only be used for the purposes for which it was designed, as described in these instructions.

If the truck needs to be used for purposes other than those specified in these instructions, you should first:

- Obtain permission from the manufacturer
- Obtain permission from the competent authorities, if applicable

The purpose of obtaining these permissions in advance is to limit danger as far as possible.

### Description of use and climatic conditions

#### Normal use

- Indoor and outdoor use.
- Ambient temperature in tropical and Nordic regions ranging from -10°C to 45°C
- Start capability from -10°C to 45°C.
- Maximum start time of 20 seconds
- Use at up to 2000 metres above sea level.

#### Special use (partly with special measures) for trucks equipped with Gel or Lead batteries

- Use, for example, in the event of abrasive dust (such as AL203), lint, acid, leach, salt and incombustible substances.
- Ambient temperature in tropical regions up to 55 °C.
- Start capability at -25°C.
- Use at up to 3,500 metres above sea level.

## Unauthorised use

Any danger caused as a result of unauthorised use becomes the responsibility of the operator or driver and not that of the manufacturer.

Use for purposes other than those described in these operating instructions is prohibited.

Transporting people is prohibited.

The forklift truck should not be used in areas where there is a risk of fire, explosion or corrosion, or in areas that are particularly dusty.

Stacking or unstacking is not permissible on inclined surfaces or ramps.

## Explanation of symbols used

### DANGER

Compulsory procedure that must be followed to avoid life-threatening danger or physical harm.

### WARNING

Compulsory procedure that must followed to avoid injury.

### CAUTION

Compulsory procedure that must be followed to avoid damage to and/or destruction of equipment.



### NOTE

*For technical requirements that require special attention.*



### ENVIRONMENT NOTE

*To prevent environmental damage.*

## Disposing of components and batteries

The truck is made up of different materials.

If components or batteries must be replaced and scrapped, they must be:

- disposed of
- treated or
- recycled in accordance with regional and national regulations



### NOTE

*The documentation provided by the battery manufacturer must be observed when disposing of batteries.*



### ENVIRONMENT NOTE

*We recommend working with a waste management company when disposing of components and batteries.*

## Disposing of components and batteries



2

---

**Safety**

## Safety regulations

### Safety regulations

These operating instructions, which come with the truck, must be communicated to all those concerned and in particular to personnel responsible for maintenance and driving. The employer must make sure that the forklift operator has properly understood all the safety information.

Please observe the directives and safety regulations attached, in particular:

- Information concerning the use of materials handling trucks
- Regulations concerning traffic lanes and working areas
- Appropriate behaviour, rights and responsibilities of the driver
- Use in particular areas
- Information about the weight and dimensions of pallets or any other container
- Information concerning starting, driving and braking
- Information concerning maintenance and repair

- Regular checks and technical inspections
- Recycling of lubricants, oils and batteries
- Residual risks.

Care is recommended both for the user and the person in charge (employer) with regard to adhering to all safety rules concerning the use of material-handling trucks.

When instructing forklift operators, we recommend the following points are emphasized:

- The features of the truck
- The special accessories
- The specific features of the working environment.

Train the user in how to drive the truck, until it is under proper control.

Then, and only then, proceed to transferring pallets.

Forklift truck stability is guaranteed when the unit is used correctly.

## Safety regulations for handling consumables

### Permissible consumables

#### WARNING

Consumables can be dangerous.

It is necessary to follow the safety regulations when handling these substances.

Refer to the maintenance data table for the permissible substances necessary for operation.

### Oils



#### DANGER

##### Oils are flammable!

- Follow the statutory regulations
- Do not allow oils to come into contact with hot motor parts.
- No smoking, fires or flames!

#### WARNING

There is a risk of slipping on spilled oil, particularly when combined with water!

- Collect spilled oil immediately using an oil-binding agent and dispose of it in accordance with regulations.



#### DANGER

##### Oils are toxic!

- Avoid contact and consumption
- In case of inhalation of steam or fumes, breathe fresh air immediately.
- After contact with the eyes, rinse thoroughly with water (for at least 10 minutes) and then consult an eye specialist.
- If swallowed, do not induce vomiting. Seek immediate medical attention.



#### ENVIRONMENT NOTE

Oils are water pollutants!

Always store oil in containers that comply with the applicable regulations.

Avoid spilling oils.

Collect spilt oil immediately using an oil binding agent and dispose of it in accordance with regulations.

Dispose of old oils according to the applicable regulations.



#### WARNING

Prolonged intensive contact with the skin can result in loss of skin oils and cause irritation.

- Avoid contact and consumption.
- Wear protective gloves!
- After any contact, wash the skin with soap and water and then apply a skin care product.
- Immediately change soaked clothing and shoes.

## Safety regulations for handling consumables

### Hydraulic fluid



#### ⚠️ WARNING

During operation of the forklift truck, hydraulic fluids are pressurised and are hazardous to your health.

- Do not spill these fluids!
- Follow the statutory regulations
- Do not allow the fluids to come into contact with hot motor parts.
- Do not allow to come into contact with the skin.
- Avoid inhaling the spray
- Penetration of pressurised fluids into the skin is particularly dangerous if these fluids escape at high pressure due to leaks in the hydraulic system. In case of such injury, seek medical advice immediately.
- To avoid injury, use appropriate personal protective equipment (e.g. protective gloves, industrial goggles, skin protection and skin care products).



#### ENVIRONMENT NOTE

Hydraulic fluid is a water-polluting substance!

Always store hydraulic fluid in containers complying with the regulations.

Avoid spilling.

Spilt hydraulic fluid should be removed with oil-binding agents at once and disposed of according to the regulations.

Dispose of old hydraulic fluid according to regulations.

### Battery acid



#### ⚠️ WARNING

Battery acid contains dissolved sulphuric acid. This is toxic.

- Avoid contact and consumption.
- In case of injury, seek medical advice immediately.



#### ENVIRONMENT NOTE

- Dispose of used battery acid in line with the applicable regulations.



#### ⚠️ WARNING

Battery acid contains dissolved sulphuric acid. This is corrosive.

- When working with battery acid, always wear protective clothing and eye protection.
- Do not allow any acid to get onto the clothing or skin or into the eyes; if this does happen, rinse immediately with plenty of clean water.
- In case of injury, seek medical advice immediately.
- Immediately rinse away spilt battery acid with plenty of water.
- Follow the statutory regulations

## Disposal of consumables



### ENVIRONMENT NOTE

*Materials that have to be disposed of following maintenance, repair and cleaning must be systematically collected and disposed of in accordance with regulations. Observe the national regulations for your country. Work may only be carried out in areas designated for this purpose. Take care to minimise, as far as possible, any impact on the environment.*

- Any spillage of fluids such as hydraulic oil, brake fluid or gear lubricant oil must be immediately soaked up with an oil-binding agent.
- The regulations for disposal of used oil are applicable.
- Any spillage of battery acid must be neutralised immediately.

## Emissions

## Emissions

## Noise emission values

Calculated during the test cycle performed in accordance with standard EN 12053.

Acoustic pressure level in the driver's compartment			
EXH14 truck	L <sub>PAZ</sub>	=	57 dB (A)
EXH16 / EXH18 / EXH20 / EXH20+ trucks			63 dB (A)
Uncertainty	K <sub>PA</sub>	±	2.5 dB (A)



## NOTE

Lower or higher noise values may occur when using industrial trucks, e.g. due to the mode of operation, environmental factors and other sources of noise.

## Vibration characteristics for vibrations to which the body is exposed

The values were determined according to EN 13059 using trucks with standard equipment according to the datasheet (driving over test course with humps).

Specified characteristics for upper limb vibrations	
Vibration characteristics	< 2.5 m/s <sup>2</sup>



## NOTE

The vibration characteristics for bodily vibrations cannot be used to determine the actual load level of vibrations during operation. This depends on the operating conditions (state of ground, mode of operation etc.) and should therefore be determined on site, where appropriate. It is mandatory to specify the hand-arm vibrations even where the values do not indicate any hazard, as in this case.

## Residual dangers, residual risks

Despite all operational precautions and compliance with standards and rules, the possibility of additional risks when using the truck cannot be entirely excluded.

The truck and all its components comply with the regulations relating to current applicable safety rules.

Persons in the vicinity of the truck must be particularly cautious and react immediately in the event of any malfunction, incident, breakdown etc.

### WARNING

Personnel in contact with the truck must be informed of the risks related to using the truck.

These operating instructions draw your attention to the safety rules.

The risks are:

- Escape of consumables due to leaks, ruptured lines and tanks etc.
- Risk of accident when driving over difficult ground such as slopes, soft or irregular surfaces or in poor visibility etc.

## Stability

Forklift truck stability is guaranteed only if the unit is used according to the indicated recommendations.

It is not guaranteed in the event of:

- cornering at excessive speeds
- moving with the load raised
- moving with a load that is protruding to the side (e.g. sideshift),
- turning and driving diagonally across descents or ascents,
- driving on descents or ascents with the load on the downhill side,
- loads that are too wide or too heavy,
- driving with a swinging load,
- ramp edges or steps.

- Falling, tripping etc. when moving on the industrial truck, especially in the wet, with leaking consumables or icy surfaces.
- Loss of stability due to the load being unstable or the load slipping etc.
- Risk of fire and explosion due to batteries and electrical voltages.
- Human error - Disregarding safety regulations.

It is important to adjust the speed of the truck depending on the load and ground conditions.

The stability of the truck has been tested to the latest standards. These standards only take account of the static and dynamic tilting forces that can arise during operation that complies with the specifications and operating rules. Risks caused by misuse or incorrect operation that jeopardise the stability cannot be ruled out in extreme situations.

## Definition of responsible persons

### Definition of responsible persons

#### Operating company

The operating company is the natural or legal person or group who operates the truck or on whose authority the truck is used.

The operating company must ensure that the truck is only used for its intended purpose and in compliance with the safety guidelines set out in these operating instructions.

The operating company must ensure that all users read and understand the safety information in these instructions.

The operating company is responsible for the scheduling and correct performance of regular safety checks.

It is recommended that these checks comply with national performance specifications.

#### Specialist

A specialist is deemed to be:

- A person whose experience and technical training has allowed him to develop relevant knowledge of industrial trucks
- A person who is also familiar with national health and safety regulations and generally recognised technical directives and conven-

tions (standards, VDE regulations, technical regulations of other European Union member states or countries that are signatories to the treaty that established the European Economic Area). This expertise allows him to assess the condition of industrial trucks in terms of health and safety

#### Drivers

This truck may only be driven by suitable persons who are at least 18 years of age, have been trained in driving, have demonstrated their skills in driving and handling loads, and have been specifically designated to drive the truck. Specific knowledge of the truck is also necessary.

The driver must be familiar with the operating instructions and have access to them at all times.

The driver must:

- Have read and understood the operating instructions
- Have familiarised himself with safe operation of the truck
- Be physically and mentally able to drive the truck safely

#### Driver rights, duties and rules of behaviour

The driver must be duly informed of his rights and duties.

The driver must be granted the required rights.

The driver must wear protective equipment (protection suit, safety helmet, industrial goggles and protective gloves) that is appropriate for the conditions, the task and the load to be lifted. The driver must also wear safety footwear to be able to drive and brake in complete safety.

#### DANGER

**The use of drugs, alcohol or medications that affect reactions impair the ability to drive the truck.**

Individuals under the influence of the above-mentioned substances are not permitted to perform work of any kind on or with the truck.



## Definition of responsible persons

**Prohibition of use by unauthorised persons**

The driver is responsible for the truck during working hours. He must not allow unauthorised persons to operate the truck.

When leaving the truck, the driver must secure it against unauthorised use.

## Safety tests

### Safety tests

#### Regular safety inspection of the truck

##### Safety inspection based on time and extraordinary incidents ▷

The operating company (see chapter entitled "Definition of responsible persons") must ensure that the truck is checked by a specialist at least once a year or after noteworthy incidents.

As part of this inspection:

- A full check of the technical condition of the truck in terms of accident safety must be performed
- The truck must be thoroughly checked to detect any damage that may have been caused by improper use
- A test log must be created.

The results of the inspection must be retained until at least a further two inspections have been carried out.

The inspection date is indicated by an adhesive label on the truck.

- Arrange for the service centre to perform periodic safety inspections on the truck.
- Observe the guidelines for tests carried out on the truck in accordance with FEM 4.004.

The operator is responsible for ensuring that any defects are remedied immediately.

- Contact your service centre.



#### NOTE

*Observe the regulations in force in your country.*

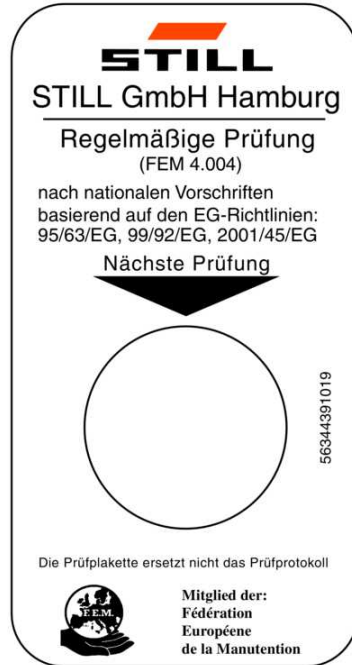

**3**

---

## **Overviews**

## Overview

## Overview

General view of EXH 14, EXH 16, EXH 18, EXH 20 and EXH 20+ trucks

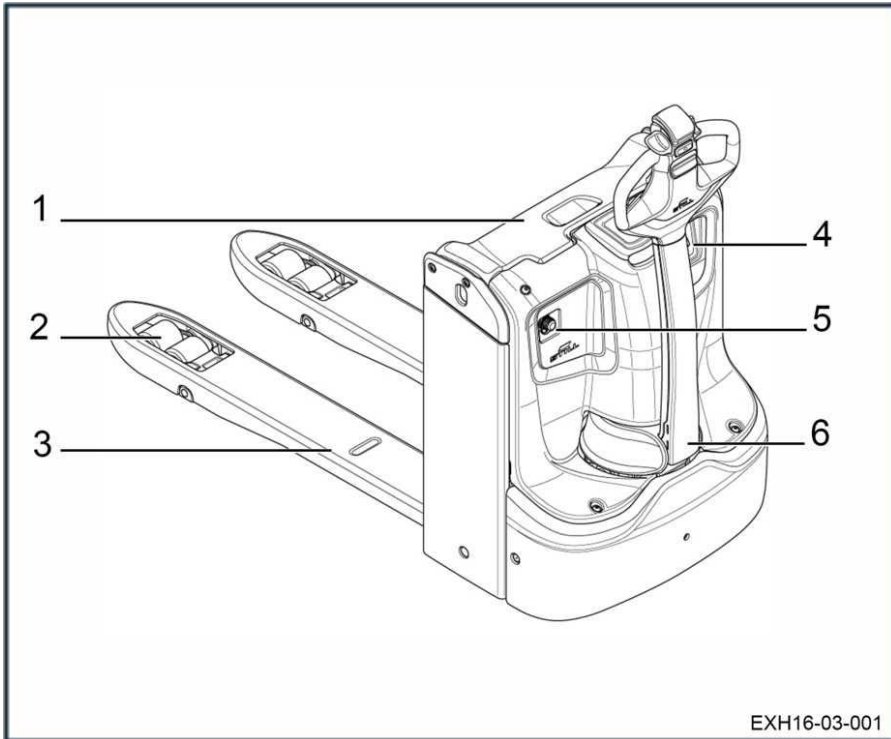

- 1 Battery hood
- 2 Wheels
- 3 Load arms

- 4 Key or electronic key
- 5 Diagnostic connector
- 6 Tiller

## View of the technical compartment

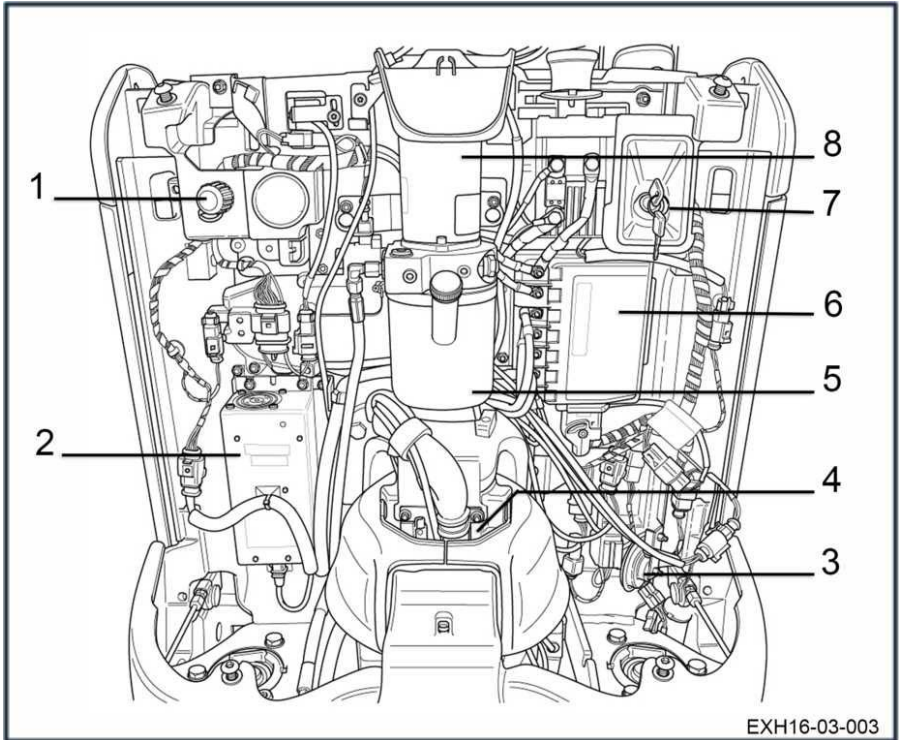

EXH16-03-003

- |   |                      |   |   |
|---|----------------------|---|---|
| 1 | Diagnostic connector | 6 | Controller  |
| 2 | On-board charger     | 7 | Ignition key or electronic key (depending on the version) |
| 3 | Horn                 | 8 | Pump unit   |
| 4 | Traction motor       |   |   |
| 5 | Tank                 |   |   |

## Overview

## General view of EXH-SF 16C and EXH-SF 20C trucks

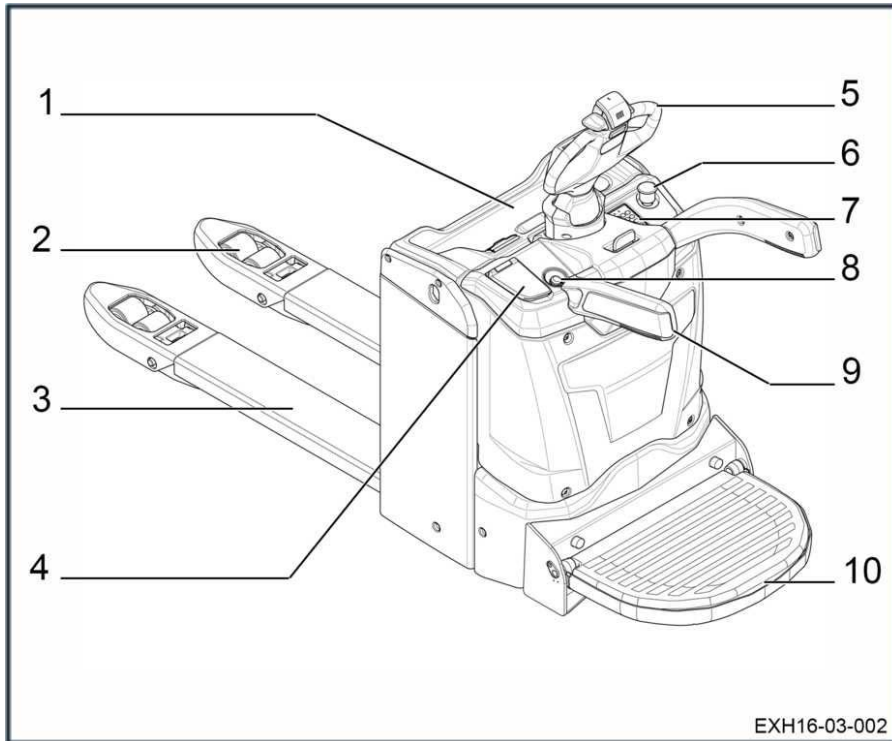

- |   |   |    |  |
|---|---|----|--|
| 1 | Battery hood  | 6  | Emergency off switch   |
| 2 | Wheels  | 7  | Ignition key or digital control panel (depending on the model) |
| 3 | Load arms   | 8  | Diagnostic connector   |
| 4 | Plug for external charger or opportunity charging (depending on models) | 9  | Side protection guardrails                                     |
| 5 | Tiller  | 10 | Platform   |

## Operating and display devices

### Truck controls

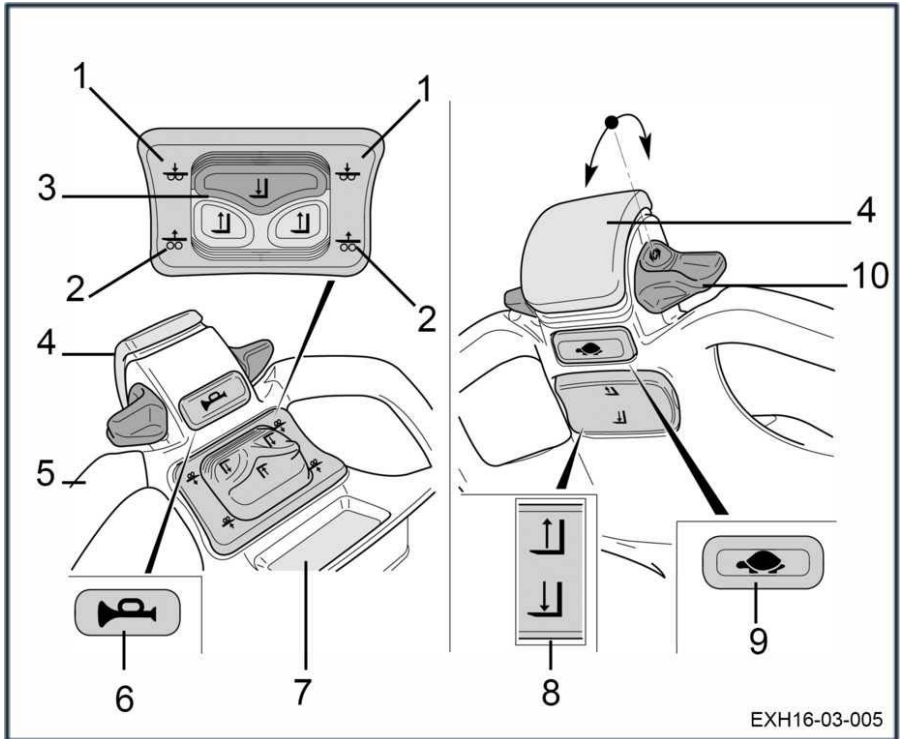

EXH16-03-005

- |   |   |
|---|---|
| <ul style="list-style-type: none"> <li>1 Initial lift lowering control</li> <li>2 Initial lift lifting control</li> <li>3 Fork lifting and lowering control</li> <li>4 Double throw safety switch</li> <li>5 Tiller handle</li> <li>6 Horn</li> </ul> | <ul style="list-style-type: none"> <li>7 Display</li> <li>8 Fork lifting and lowering button when the Tortoise button is activated</li> <li>9 Tortoise button</li> <li>10 Drive switch</li> </ul> |
|---|---|

## Operating and display devices

## Electronic key (option)

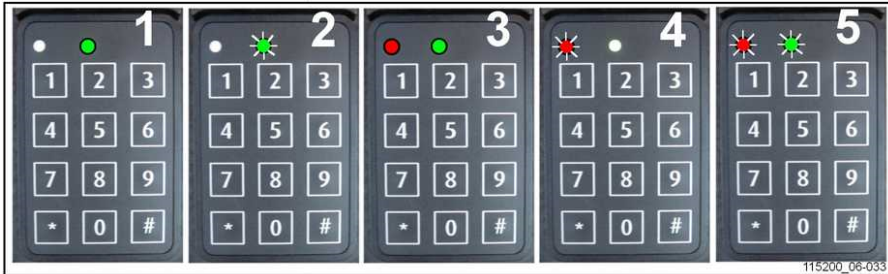

- |   |                              |   |                                    |
|---|------------------------------|---|------------------------------------|
| 1 | Switch ON (operating mode)   | 4 | Key fault or incorrect code        |
| 2 | Switch OFF and awaiting code | 5 | Time delay of automatic switch-off |
| 3 | Programming mode active      |   |                                    |

Operation	Enter	Status of LEDs	Comments
<b>USE</b>			
ON	*12345# (by default)	<ul style="list-style-type: none"> <li>○ red off ● continuous green (1) (correct PIN)</li> <li>● red flashing ○ green off (4) (incorrect PIN)</li> </ul>	12345 default PIN
OFF	# (3 seconds)	○ red off ● green flashing (2)	Truck power off

<b>PROGRAMMING (truck switch OFF only (2))</b>			
<b>ADMINISTRATOR CODE ESSENTIAL FOR ALL ELECTRONIC KEY SETTINGS</b>	*00000000# (by default)	● continuous red ● continuous green (3)	Once the LEDs have gone out, the electronic key automatically reverts to "operating mode".
New operator code	*0*45678#	○ red off ● green flashing (2) (code accepted)	Example of new operator code: 45678
Allocating operator codes	*2*54321#	○ red off ● green flashing (2) (code accepted)	*2*: operator reference 10 options from 0 to 9
Deleting operator codes	*2*#	○ red off ● green flashing (2) (deletion accepted)	*2*: operator reference (between 0 and 9)
Modifying administrator codes	*912345678#	○ red off ● green flashing (2) (code accepted)	



PROGRAMMING (truck switch OFF only (2))			
Restoring the initial administrator code			To reactivate the default administrator code (00000000), please contact your agent or nearest dealer.
Activating the automatic switch-off	* * 2 * 1 #	<ul style="list-style-type: none"> <li>● red flashing ● green flashing (5) (5 seconds before switch-off)</li> </ul>	Power switches off automatically after 10 minutes (600 seconds by default) if the truck is not in use.
Setting the time delay of the automatic switch-off	* * 3 * 6 0 #	<ul style="list-style-type: none"> <li>○ red off ● green flashing (2) (value accepted)</li> </ul>	Example: automatically switches off after 1 minute (60 seconds) if not in use. Minimum setting = 10 seconds/maximum = 3000 seconds
Deactivating the automatic switch-off	* * 2 * 0 #	<ul style="list-style-type: none"> <li>○ red off ● green flashing (2) (command accepted)</li> </ul>	

## Operating and display devices

## Basic display operating unit

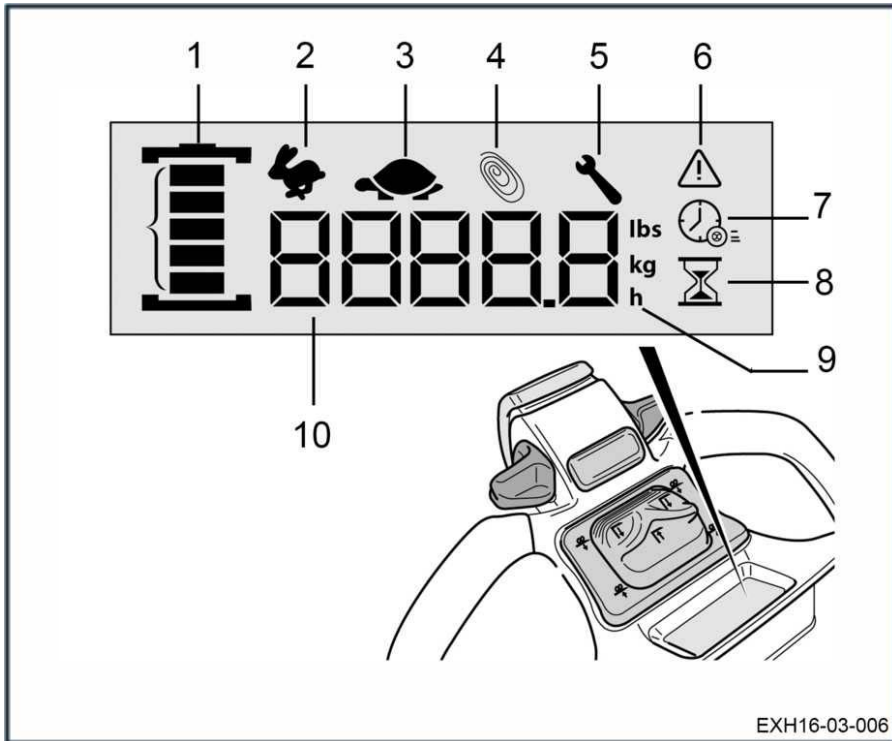

- |   |                         |    |   |
|---|-------------------------|----|---|
| 1 | Battery indicator       | 7  | Icon indicating the remaining operating hours for the truck |
| 2 | Hare icon               | 8  | Icon indicating the total operating hours for the truck     |
| 3 | Tortoise icon           | 9  | Units of measurement  |
| 4 | Blue-Q icon             | 10 | Hour meter/weight/warning code                              |
| 5 | Maintenance interval    |    |   |
| 6 | Warning indicator light |    |   |

# Markings

## Labels

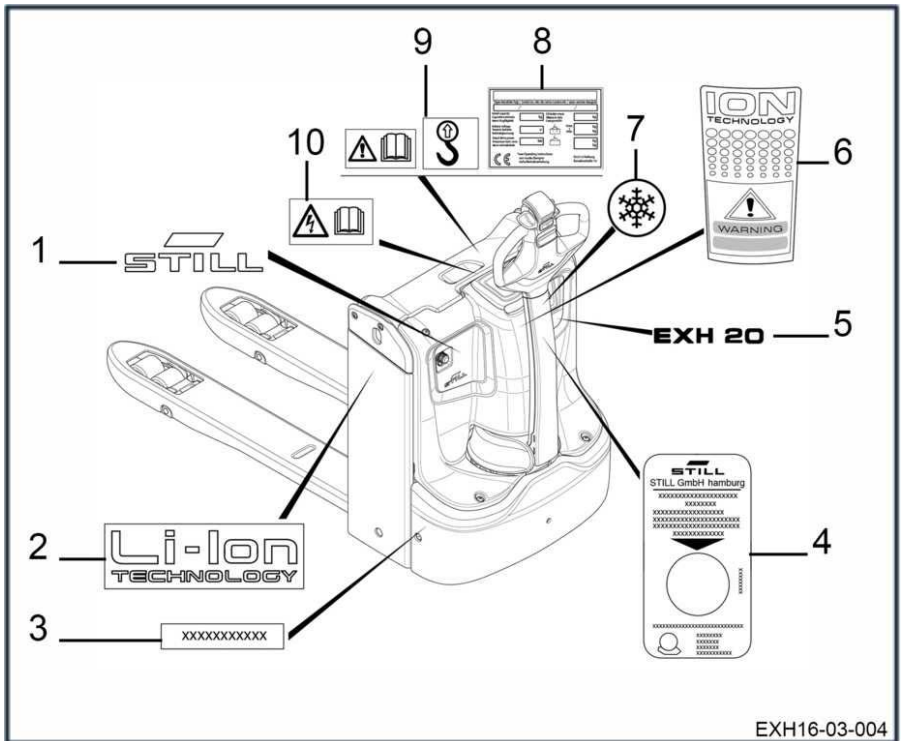

- |  |  |
|--|--|
| <ul style="list-style-type: none"> <li>1 Brand label</li> <li>2 Lithium-ion label</li> <li>3 Serial number label</li> <li>4 Next inspection label</li> <li>5 Truck type label (depending on model)</li> <li>6 Lithium-ion warning label</li> </ul> | <ul style="list-style-type: none"> <li>7 Cold store label</li> <li>8 Identification label</li> <li>9 Slings label and "Danger instructions" label, consult the operating instructions</li> <li>10 "Electrical danger" label, consult the operating instructions</li> </ul> |
|--|--|

## Markings

## Serial number



## NOTE

Indicate the serial number for all technical enquiries.

The serial number contains the following information:

- 1 Production location
- 2 Type
- 3 Year of production
- 4 Count number

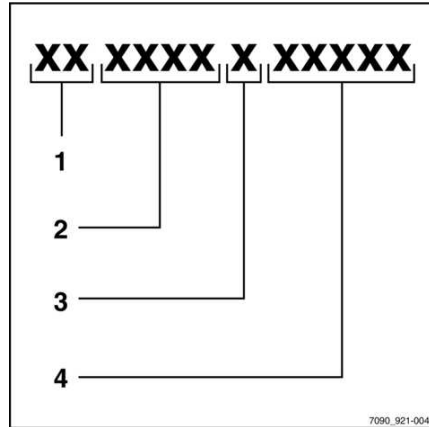

4

---

Use

## Technical description

### Technical description

The EXH 14, EXH 16, EXH 18, EXH 20, EXH 20+, EXH-L 16, EXH-L 20, EXH-SF 16C and EXH-SF 20C electric pallet trucks are used to move pallets or containers.

Their small size, their ease of driving and their performance make these trucks very appropriate for loading and unloading operations.

They are pedestrian models.

The EXH-SF 16C and EXH-SF 20C models are equipped with a platform and side protection guardrails. They can be used in pedestrian mode or in ride on mode.

The EXH-L 16 and EXH-L 20 are equipped with a small mast.

### Features

Speed during pedestrian driving:

- 6 km/h unladen
- 6 km/h laden

### Capacity:

- In pallet truck mode: from 1400 to 2000 kg depending on the model

### Drive system

The truck drive system comprises:

- Power traction motor 1.1 kW (EXH 14 models) and 1.3 kW (EXH 16, EXH-L 16, EXH-SF 16C, EXH 18, EXH 20, EXH 20+, EXH-L 20 and EXH-SF 20C models).
- A KWPC controller to control traction and lift.
- Power pump unit 1 kW (EXH 14, EXH 16 and EXH 18 models) and 1.2 kW (EXH-L16, EXH-SF 16C, EXH 20, EXH 20+, EXH-L 20 and EXH-SF 20C models).

### Steering

A long or short, robust, ergonomic tiller allows the operator to direct the drive/steering wheel effortlessly.

The various controls: forward travel, reverse travel, lifting and lowering of the load arms

and the horn are grouped together at the end of the tiller.

For safety reasons, the tiller automatically returns to the upper position when it is released.

The speed of the truck is limited to 6 km/h in both directions of travel.

### Batteries

Power is supplied by:

- A lead battery
- A gel battery
- Or a lithium-ion battery (the truck therefore has specific characteristics)

Trucks EXH 14, EXH 16, EXH-L 16, EXH-SF 16C, EXH 18, EXH 20, EXH 20+, EXH-L 20 and EXH-SF 20C are compatible with the old and new generation lithium-ion batteries. No specific label is affixed in the battery compartment to state this.

The types of battery removal that are available are as follows:

- Vertical access
- Side access

These different battery types are not available on all models.

### Braking

The truck is equipped with two brake systems:

- an electric counter-current brake:
  - when releasing the drive switch.
  - By reversing the drive direction.
  - controlled by the rear safety button.
- an electromagnetic brake:
  - for safety purposes, controlled by the emergency off switch
  - for safety purposes, controlled by whether the tiller is in the upper or lower position
  - for parking, applied when the supply is cut

## Stabilisers

The 5-point chassis has 2 suspended stabilisers which compensate for ground irregularities.

## Driver's compartment

The tiller groups together control functions: steering, lift, forward and reverse traction, initial lift, horn and double throw safety switch.

The various models are equipped with:

- An emergency off switch.
- A display.
- A diagnostic connector.

## Equipment available as standard or as additional options:

That can be added to the truck:

- Load backrest.
- Load wheels: single, double or triple wheels.
- Lithium-ion battery.
- Creep speed.
- Central refilling system.
- Cold store (-35°C).

## List of checks prior to start-up

### List of checks prior to start-up

#### WARNING

Damage or other defects on the truck or attachments (special equipment) can result in accidents.

If damage or other faults are noticed on the truck or attachments (special equipment) during the following inspections, do not use the truck until it has been properly repaired. Do not remove or disable the safety systems and switches. Do not change the pre-set values.

Before start-up, ensure that the truck operates correctly.

To do this, perform the following checks:

- The load arms must not show any signs of noticeable damage (for example: bending, cracks, significant wear).
- Check that there are no signs of leaking consumables under the truck.
- Do not restrict the field of vision. Ensure the visible area specified by the manufacturer is observed.
- Attachment parts (special equipment) must be properly secured and function according to their operating instructions.
- Damaged or missing stickers must be replaced in compliance with the marking position table.
- The roller channels must be coated in a visible layer of grease.
- The wheels must show no signs of defects or heavy wear. They must be mounted correctly.
- Check that there are no foreign objects that could hinder the operation of the wheels and rollers.
- The warning devices (horn etc.) must work.
- The battery hood must be closed.
- Check that the hoods are correctly positioned.
- The operator must be qualified to drive the truck. The operator must be able to reach the controls and operate them (especially the anti-crush device). Do not obstruct access to the controls.

Please inform your supervisor if you notice any defects.



## Starting up

### **⚠ DANGER**

#### **Risk of sparks**

Using the truck with the battery hood open is prohibited.

- Check that the battery hood is closed.
- Check that the battery is locked.

To start the truck, proceed as follows:

- Pull the emergency off switch (1) to the top position ▷
- Turn the switch key (2) or enter the PIN on the electronic key screen and start the truck.

The display switches on.

The brake is automatically disengaged.

- Lower the tiller then reposition in the rest position to unblock truck use.
- Raise the load arms a few centimetres.



#### **NOTE**

*Always adjust the speed to suit the route, any dangers and the load. Use the truck on ground that has the correct surface and hardness.*

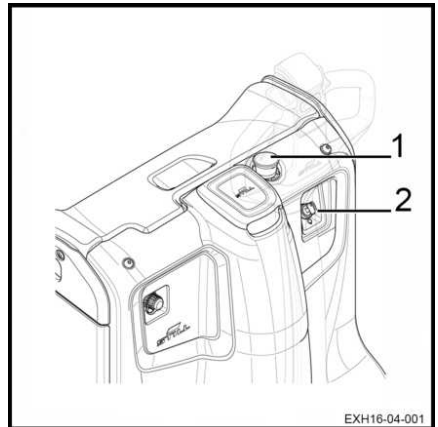

EXH16-04-001

### **⚠ WARNING**

Risk of accident or loss of load.

Driving on slopes steeper than 10% is prohibited due to braking capacity and stability. The load being transported could tip over.

## Starting up

- Tilt the tiller into the drive area (2).



### NOTE

*In areas (1) and (3), the electromagnetic brake is applied and it is not possible to drive the truck.*

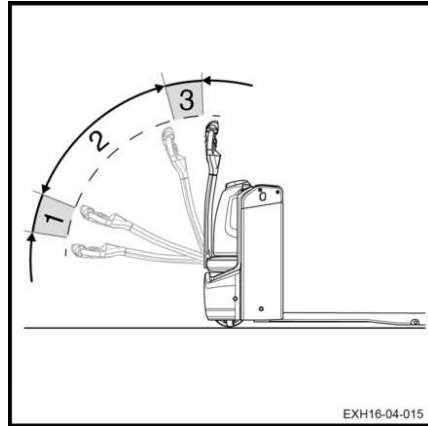

## Checks and actions prior to commissioning

### Checking the emergency off

To check the operation of the emergency off switch, proceed as follows:

- Start up the truck.
- Drive the truck.
- Press the emergency off switch (1).

The truck stops immediately. The truck power supply is cut. The electrical controls and motors are no longer supplied with power.

- The brake is applied.
- Pull the emergency off switch (1).

The functions are available again.

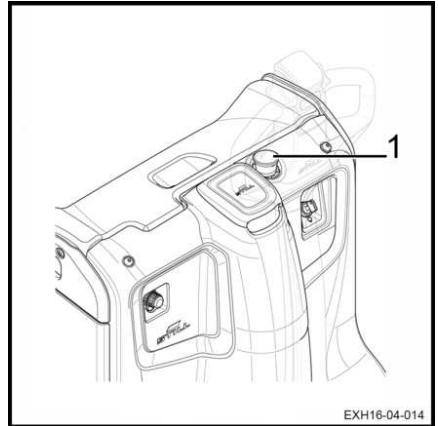

#### NOTE

*Ensure that the stabiliser wheels operate correctly. This influences braking effectiveness.*

### Checking the brake

#### NOTE

*Perform this check on a flat surface.*

- Start the machine moving.
- Tilt the tiller in areas (1) and (3).

In these two areas, the machine is braked and the drive unit is no longer powered.

Releasing the tiller in the drive area (2) sends the tiller into area (3) and cuts traction.

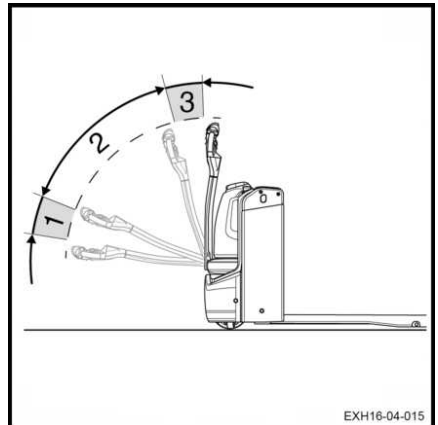

## Checks and actions prior to commissioning

### Checking the horn

- Press the horn button (5) located on the upper part of the tiller.
- The horn sounds.

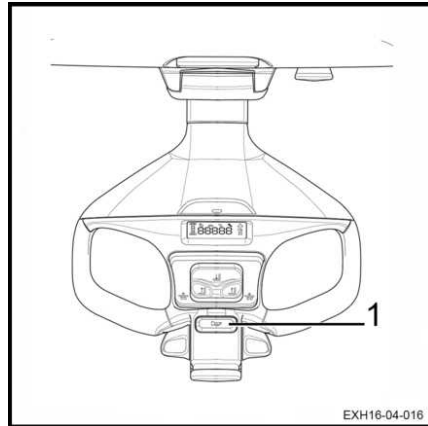

### Checking the anti-crush safety device

#### Anti-crush safety function

The machine moves in the opposite direction when the anti-crush button (2) is pressed.

If the truck is being operated in narrow areas (such as in a lift for example), the operator may get stuck against the wall if care is not taken. Without an anti-crush safety device, the tiller could injure the operator.

The truck immediately moves off in the opposite direction when the anti-crush device on the tiller head comes into contact with the driver's body. When the operator moves away from the anti-crush safety device, the machine stops even if a drive direction is selected again.

Normal operation may be resumed after releasing the drive switches.

### Checking the anti-crush safety device



#### **WARNING**

Ensure that the test zone is free of people and objects, both in front of and behind the truck.

- Move the drive switch (1) or (3) to move the truck towards you.
- Activate the anti-crush safety device (2).

The truck stops and accelerates in the opposite drive direction.

- Release the anti-crush safety button.

The truck stops.

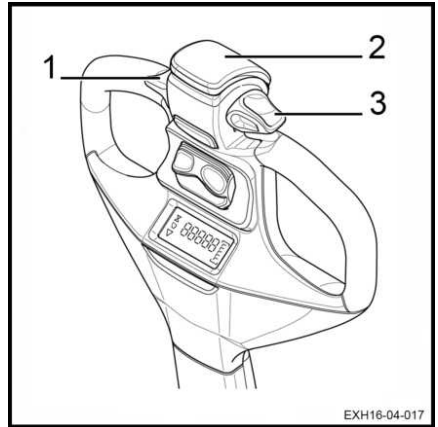

## Truck operating instructions

### Truck operating instructions

The trucks are designed for indoor and outdoor use in non-hazardous atmospheres. The temperature should be between -10°C and +45°C and the relative humidity of the air less than 95%.



#### NOTE

*A cold store option is available for lower temperatures.*

The places where the truck is used must comply with the applicable regulations (condition of the ground, lighting etc.).

#### The trucks must be used on dry, clean and flat ground.

Before using the truck, it is essential to check the working environment. This check can take the form of visual inspection.

The work area must be clear. The truck's path must be free of obstacles and people.

The forklift operator must be alert to anything that might prevent manoeuvres being carried out safely. The following may create a potential danger:

- A person near the truck
- The forklift operator must not use an MP3 player or any other electrical equipment that could impair awareness of his/her surroundings
- There must be no signs of oil or grease on the floor

The forklift operator must take care when transporting a load. The load dimensions can interfere with manoeuvres and restrict the field of vision. The speed of the truck must also be reduced as the truck could tip over when braking or cornering.

The loads must be consistent, with a maximum recommended height of 2 m.

For uses other than those shown above, please consult the After-Sales Service Centre.

It is important to use pallets that are in good condition.

Speed must be reduced when moving over obstacles to prevent the truck from becoming unbalanced and vibrations in the forklift operator's arms.

The trucks can drive across ramps and shallow inclines. With an initial lift, they can cross larger obstacles.

#### WARNING

Risk of loss of stability

- Always adapt your driving to the ground conditions (uneven surfaces etc.), particularly hazardous working areas and the load.



#### NOTE

- *To prevent the bottom of the load lift system from scraping the ground, always move the load arms to the raised position before setting off*
- *Always switch off the ignition before leaving the truck*

#### WARNING

Risk of injury

**Always keep your hands near the controls. Never put your hands near moving parts and assemblies without first lowering the load arms to the ground and disconnecting the battery.**

For effective protection, safety shoes must be worn.

#### WARNING

Driving safety guidelines:

- The driver must drive slowly around corners and when entering narrow passageways.
- The driver must always maintain a safe braking distance from vehicles or people in front of him.
- The driver must avoid stopping suddenly, making U-turns too quickly and overtaking in dangerous areas with poor visibility.

#### CAUTION

Risk of injury

Before using a side access truck, check that the battery is correctly locked.

## Using the Basic display-operating unit

### Battery indicator

The battery indicator (1) shows the battery charge status. Each bar (2) represents 20% charge.

#### Battery fully charged:

Five bars (2) are displayed. The number of bars on the display decreases as the battery discharges.

#### Battery with 20% remaining charge:

Only the last bar (3) is illuminated. It is advisable to charge the truck battery.

For a lithium-ion battery, the last bar (3) remains illuminated (continuous light).

For another battery type, such as a lead-acid battery, the last bar (3) remains illuminated with a flashing light.

#### Battery with 10% remaining charge:

The battery must be recharged immediately.

For a lithium-ion battery, only the last bar (3) remains illuminated with a flashing white light.

For another battery type, such as a lead-acid battery, only the last bar (3) remains illuminated with a continuous red light.

With less than 10% residual charge, truck performance may be limited (reduction of maximum speed, prevention of fork lifting etc.).

#### Battery fully discharged:

The battery must be recharged immediately.

Only the last bar (3) remains illuminated with a flashing red light.

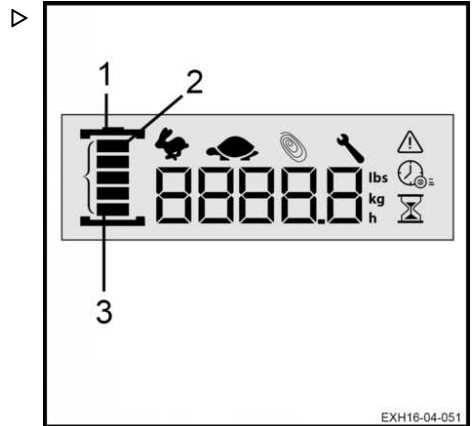

Charge level	Lithium-ion battery	Other battery types	Truck performance	Required action
100%	Five bars displayed on the screen	Five bars displayed on the screen	Optimum performance	
20%	The last bar (3) remains illuminated Continuous light	The last bar (3) remains illuminated Flashing light	Normal performance	Battery charging recommended

## Using the Basic display-operating unit

Charge level	Lithium-ion battery	Other battery types	Truck performance	Required action
10%	The last bar (3) remains illuminated Flashing white light	The last bar (3) remains illuminated Continuous red light	Limited performance	Please charge the battery
0%	The last bar (3) remains illuminated Flashing red light	The last bar (3) remains illuminated Flashing red light	The truck no longer works	Please charge the battery

## Different performance modes

The truck has three performance modes:

- Hare mode
- Tortoise mode
- Blue-Q mode

Only one mode can be activated at a time.

### Hare icon (1)

When the Hare icon (1) is illuminated, truck performance is at maximum.

### Tortoise icon (2)

When the Tortoise icon (2) is illuminated, truck performance is automatically reduced and limited.

### Blue-Q icon (3)

When the Blue-Q icon (3) is illuminated, truck performance is optimised to save as much battery power as possible.



### NOTE

*For each performance level, the corresponding icon switches on when the level is activated and switches off when it is deactivated.*

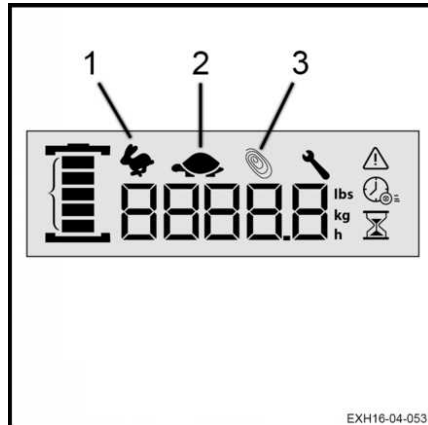



## Other display icons

### The maintenance interval (1)

When this indicator flashes, this means that the maintenance interval is approaching. Contact the After-Sales Service Centre for further information.

If the indicator is illuminated continuously, this means that maintenance is overdue. Contact the After-Sales Service Centre.

### The remaining number of operating hours for the truck (2)

This icon indicates that the value displayed in the central numeric field corresponds to the remaining number of operating hours for the truck.

### The number of operating hours for the truck (3)

This icon (6) indicates that the value displayed in the central numeric field corresponds to the total number of operating hours for the truck. This value is usually displayed when the truck is switched on.

### The units of measurement (4)

When the "h" icon is illuminated, the value displayed on the screen is in operating hours.

When the "kg" icon is illuminated, the weight displayed on the screen is in kg.

When the "lbs" icon is illuminated, the weight displayed on the screen is in pounds.

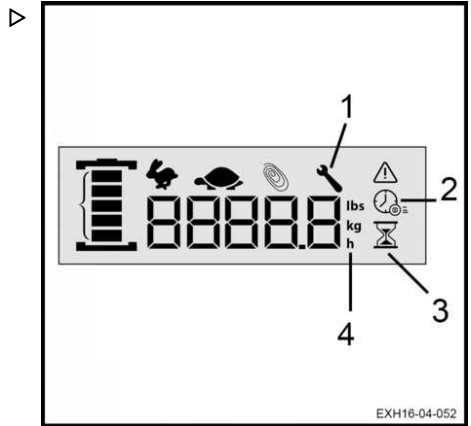

## Using the Basic display-operating unit

### Warnings on the display

#### Incorrect switch-on sequence

The warning indicator light (1) illuminates on the display and the standard information (for example, the number of operating hours) remains on the display in the field (2).

The warning indicates that the forklift operator has performed an incorrect switch-on sequence. The forklift operator must release all the controls (tiller, drive switches etc.) then wait for a while before using the truck again.

If the warning reappears, switch the truck off and on again.

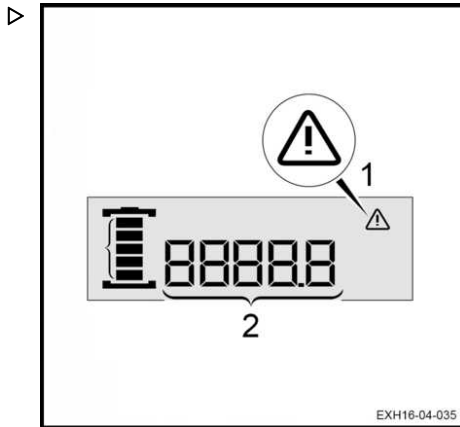

#### Generic warning

The warning indicator light (1) illuminates on the display and an error code appears in the field (2).

The warning indicates that there may be various issues with the truck.

Switch the truck off and on.

If the warning reappears at start-up, contact the After-Sales Service Centre. During this time, park the truck in a safe and suitable place.

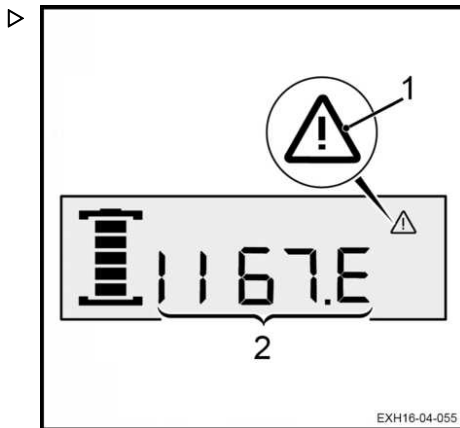

### Specific warning for battery charging

This warning relates specifically to charging the battery via the on-board charger (if option available).

The warning indicator light (1) illuminates on the display. Error is displayed in the field (2) and segments (3) and (4) flash.

The warning indicates that there are issues with charging the truck via the on-board charger.

Switch the truck off and on.

If the warning reappears at start-up, contact the After-Sales Service Centre.

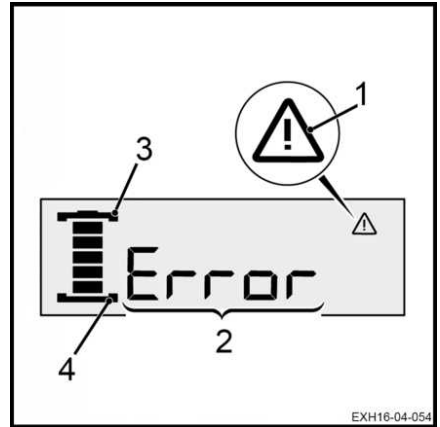

## Driving safety guidelines

### Driving safety guidelines

#### Behaviour when driving

Operators must obey the same rules within the plant as on the road. They must drive at speeds appropriate for the driving conditions.

Therefore, they must drive slowly:

- When cornering
- Through narrow passageways
- Through swing doors
- In low-visibility areas
- When the roadway is uneven

Operators must always maintain a safe braking distance from vehicles or people in front of them. They must always maintain control of the truck. They must avoid sudden stops, making fast U-turns, overtaking other vehicles in potentially hazardous or low-visibility areas.

Driving the truck while sitting on the dashboard is prohibited. The operator must be resting against the seat.

These trucks are designed to be used as a pallet stacker, double pallet stacker and pallet truck. Therefore:

- Never sit on the dashboard to drive the truck
- The truck must not be used as a stepladder
- The truck is not designed to transport people
- Operators must always stay within the truck clearance
- Stay in the safety area (working area defined by the manufacturer)
- Ensure the stability of the truck and do not exceed its capacity

Use of a telephone or radio with the truck is permitted.

However, do not use these devices when driving as they may distract you.

Take a test drive on an open surface.



#### NOTE

*Drivers must wear safety shoes that fit properly to be able to drive and brake in complete safety.*

## Driving

### Defining directions

On a pedestrian-mode pallet truck, the conventional directions are:

- Forward travel (1): tiller direction
- Reverse travel (2): load arms direction

The load is positioned at the rear.

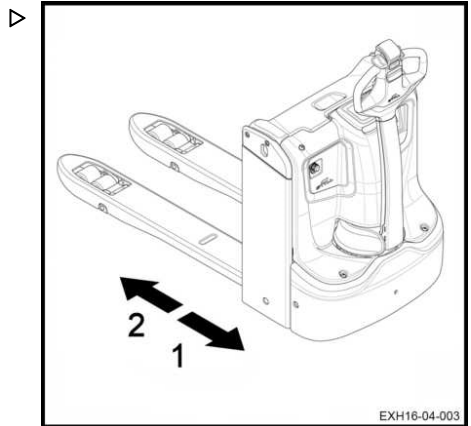

## Driving

- Turn the ignition key.
- Lower the tiller into zone (2).

### NOTE

*The truck is in the driving position in zone (2). In the lower zone (1) or the upper zone (3), the brake is applied and the traction motor is switched off.*

### DANGER

#### Risk of obstructing the use of the tiller

Do not adjust the A4-sized support to a height that is too low. This could hinder the forklift operator when driving the truck.

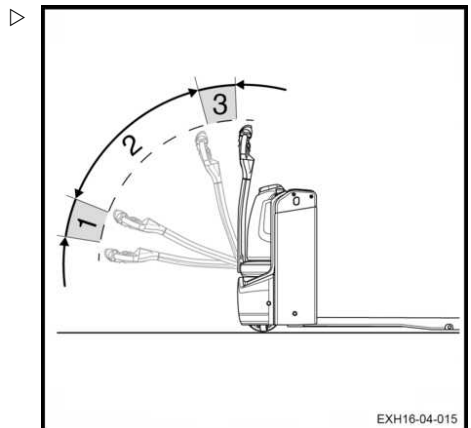

### Forward travel

## Driving

- Press the lower part (1) of the drive switch with your thumb. ▷

The speed increases with the movement of the drive switch.

When the drive switch is released, the truck brakes electrically.

### Reverse travel

- Press the upper part (2) of the drive switch with your thumb.

The speed increases with the movement of the drive switch.

When the drive switch is released, the truck brakes electrically.

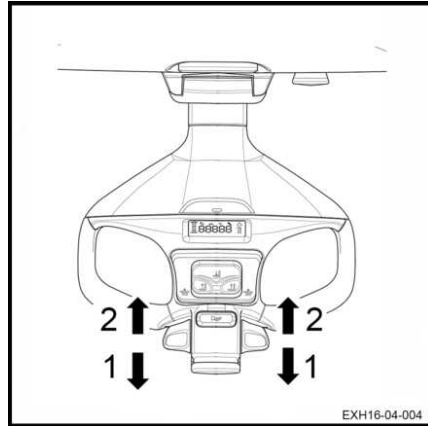

### **⚠ WARNING**

Restricted visibility

During reverse travel, visibility may be restricted. Be very careful. Make sure that the path behind is clear before travelling in reverse.

### Reversing the direction of travel

- Push the drive switch in direction (1) or (2).
- Release the drive switch.
- Operate it progressively in the opposite direction until the required speed is reached.

The truck brakes and then moves off in the opposite direction.

## Steering

A long, centred and balanced tiller, fitted with 2 handles, directly controls the drive wheel.

The length of the tiller is designed for ride-on driving.

### **⚠ WARNING**

Risk of serious injury and/or serious damage to equipment

Never use the truck with a defective steering system.

In a straight line, the tiller is centred.

To pivot the truck, proceed as follows:

- Turn the tiller clockwise: the truck turns to the left (1) in forward travel.
- Turn the tiller anti-clockwise: the truck turns to the right (2) in forward travel.

### ⚠ WARNING

Risk of serious injury and/or serious damage to equipment

Always slow down before negotiating a corner. Approaching a tight corner too fast can cause the truck to overturn.

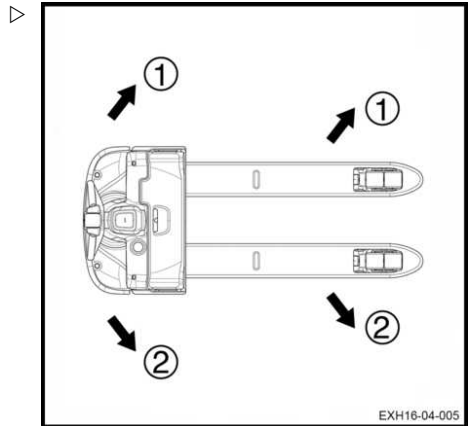

## Braking

### ⚠ WARNING

The quality of the floor surface affects the braking distance of the truck.

This should be taken into consideration when driving.

## Electromagnetic braking

The electromagnetic brake is activated automatically if one of the following conditions is met:

- The tiller is released. It is then brought back to the braking position (3) by a gas spring.
- The tiller is in braking position (3) or (1)
- The drive switch is in the neutral position
- The power supply is cut off
- The forklift operator presses the emergency off switch

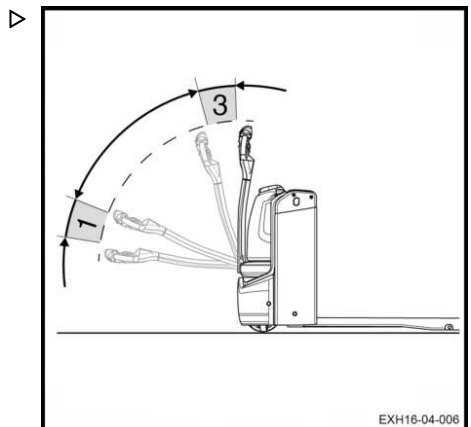

## Driving

### Braking by reversing the drive direction ▷

Braking can be achieved by reversing the drive direction:

- Move the drive switch (1) or (2) in the opposite direction until the truck stops.

### Braking by releasing the drive switch

Braking can be achieved by releasing the drive switch:

- While travelling, completely release the drive switch (1) or (2).

The brake is automatically activated. The truck is immobilised.



## Horn

The horn is positioned on the inner side of the tiller.

It is used:

- On routes where there is poor visibility
  - At junctions
  - In the event of immediate danger
- Press the button (1).

The horn sounds.

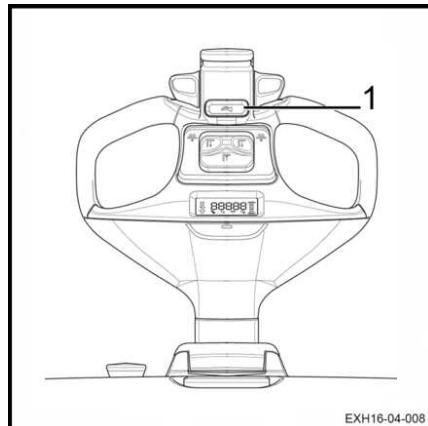



## Double throw safety switch

To protect the driver from any risk of being trapped between an obstacle and the machine, the end of the tiller is fitted with a safety flap (1). This is the anti-crush safety device.

As soon as the flap is pressed in, the machine stops immediately and moves off slowly in the direction of the fork.

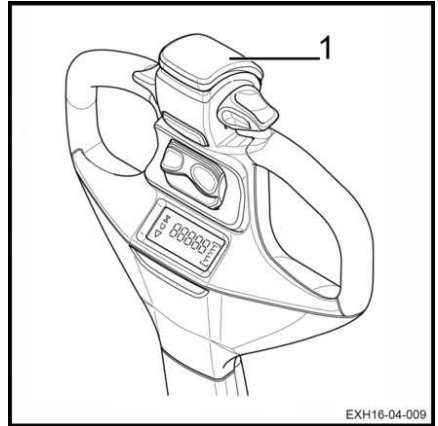

## Emergency off switch

During normal operation, the emergency off switch (1) must be pulled out.

In case of danger:

- Press the button (1) to break the electrical circuit and immobilise the truck.

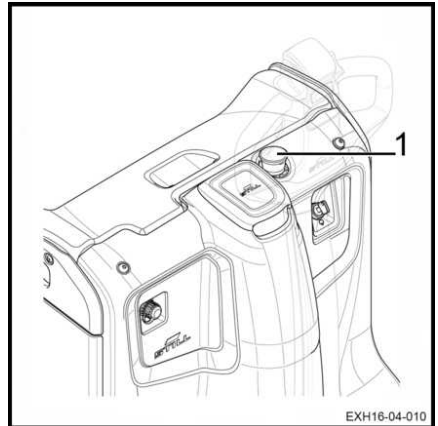

## Driving

### Tortoise button

This button makes it possible to manoeuvre the truck in confined spaces.

The tiller remains in the vertical position.

- Press the Tortoise button (1) on the tiller. Hold the button down.
- To raise the load arms, press the lift symbol (2) while holding down the Tortoise button (1).
- To lower the load arms, press the lower symbol (3) while holding down the Tortoise button (1).

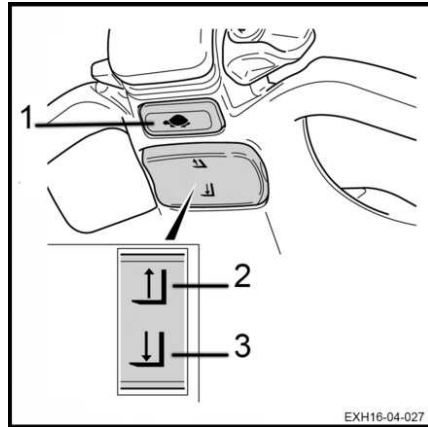

### **⚠ DANGER**

#### Risk of crushing

The idling function for manoeuvring the truck in confined spaces is automatically cancelled as soon as the tiller is tilted.

Turn the truck slightly before tilting the tiller to prevent it from moving too quickly.

This button is also used to select the truck performance mode.

Simply press the Tortoise button twice in quick succession. For example, it is possible to use maximum performance (Hare icon illuminated) or reduced performance (Tortoise icon illuminated). The icon corresponding to the selected performance level is shown on the truck display.

### Using the truck on a ramp



#### NOTE

*Incorrect use of the truck on a ramp is not recommended. It places particular stress on the traction motor, brakes and battery.*

Ramps must always be approached with caution:

- Never attempt a slope with a gradient that is greater than that specified in the truck's datasheet.
- Make sure that the ground is clean and has a non-slip surface and that the route is clear.

### Travelling up slopes

Always travel up slopes in reverse. The load faces uphill.

**i** NOTE

*Without a load, we recommend that you go up a slope forwards.*

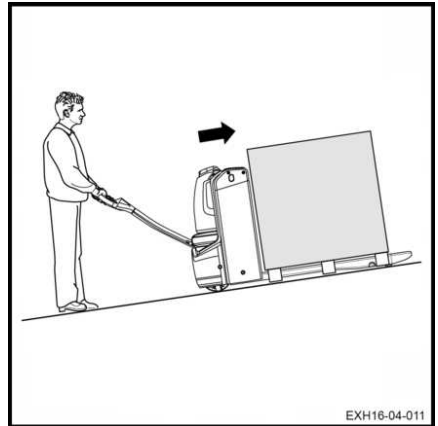

EXH16-04-011

### Travelling down slopes

Always travel down slopes forwards. The load faces uphill.

**i** NOTE

*Without a load, we recommend that you go down a slope forwards.*

In all cases, you must travel at a very low speed and brake gradually.

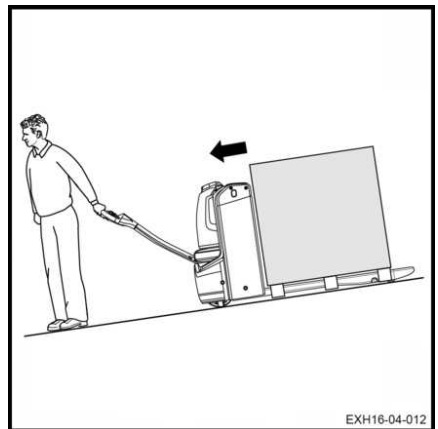

EXH16-04-012

**⚠ DANGER**

**Danger of death and/or risk of serious damage to equipment**

Never park the truck on a slope. Never make a U-turn or take a short cut on a slope.

On a slope, the forklift operator must drive more slowly.

**⚠ WARNING**

Risk of serious injury and/or serious damage to equipment

Driving on slopes steeper than 10% is prohibited due to braking capacity and stability. The load being transported could tip over.

### Starting on a ramp

Proceed as follows:

## Driving

- Move the drive switch in the required direction.
- Release the drive switch to apply the parking brake.

## Specific features of driving with folding platform trucks

### Determining the direction of travel

On a ride-on pallet truck, the conventional directions for the direction of travel are:

- Forward travel (2): Direction of load arms
- Reverse travel (1): Tiller direction

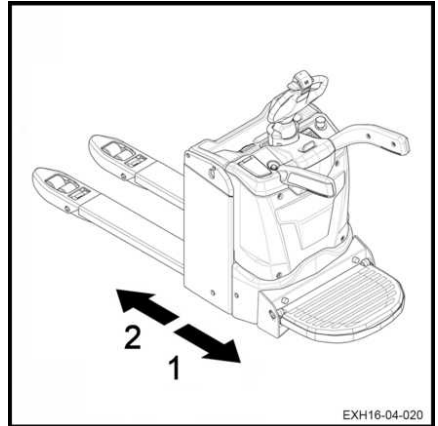

### Driving

- Turn the ignition key.
- Lower the tiller into zone (3).

#### NOTE

The truck is in the driving position in zone (3). In the lower zone (1) or the upper zone (2), the brake is applied and the traction motor is switched off.

#### DANGER

##### Risk of obstructing the use of the tiller

Do not adjust the A4-sized support to a height that is too low. This could hinder the forklift operator when driving the truck.

#### Forwards (in ride-on driving)

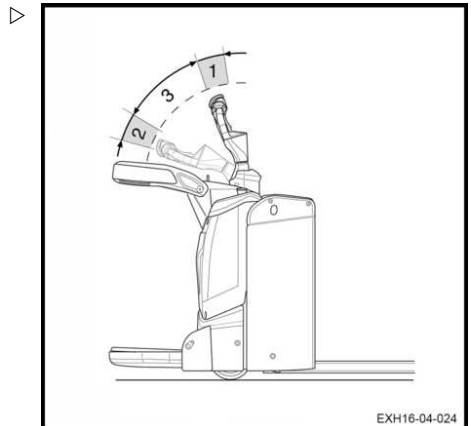

## Specific features of driving with folding platform trucks

- Press the upper part (2) of the drive switch with your thumb. ▷

The speed increases with the movement of the drive switch.

When the drive switch is released, the truck brakes electrically.

### Reverse (in ride-on driving)

- Press the lower part (1) of the drive switch with your thumb.

The speed increases with the movement of the drive switch.

When the drive switch is released, the truck brakes electrically.

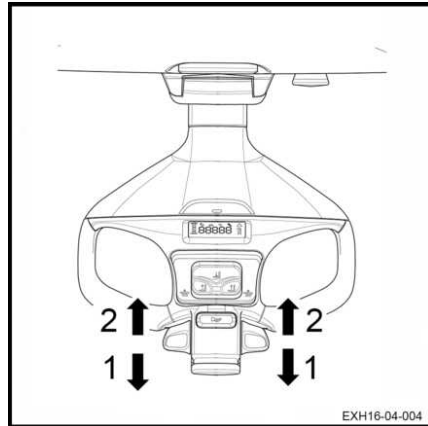

### **⚠ WARNING**

Restricted visibility

During reverse travel, visibility may be restricted. Be very careful. Make sure that the path behind is clear before travelling in reverse.

### Reversing the direction of travel

- Push the drive switch in direction (1) or (2).
- Release the drive switch.
- Operate it progressively in the opposite direction until the required speed is reached.

The truck brakes and then moves off in the opposite direction.

## Steering

### **⚠ WARNING**

Risk of serious injury and/or serious damage to equipment

Never use the truck with a defective steering system.

In a straight line, the tiller is centred.

To pivot the truck, proceed as follows:

## Specific features of driving with folding platform trucks

- Turn the tiller clockwise: the truck turns to the left (1) in forward travel.
- Turn the tiller anti-clockwise: the truck turns to the right (2) in forward travel.

**⚠ WARNING**

Risk of serious injury and/or serious damage to equipment

Always slow down before negotiating a corner. Approaching a tight corner too fast can cause the truck to overturn.

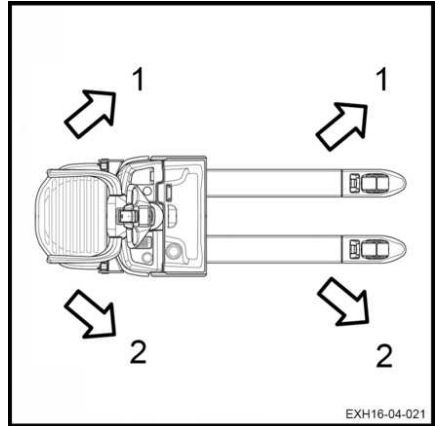

## Pedestrian driving

You can use this truck in pedestrian mode to facilitate manoeuvres in confined spaces.

- Raise the platform (6).
- Push on the tab (4) to unlock the side protection guardrails (5).
- Fold down the side protection guardrails (5).

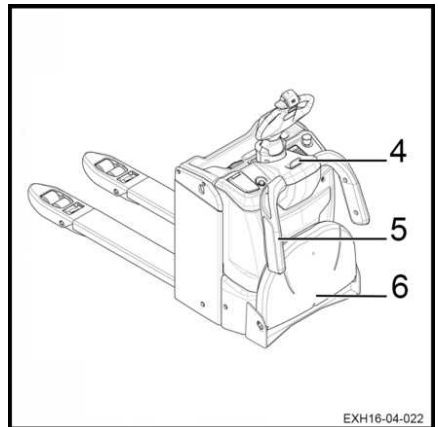

## Specific features of driving with folding platform trucks

- Tilt the tiller into the driving zone (3).

In zones (1) and (2), the electromagnetic brake is applied and it is not possible to drive the truck.



### NOTE

- *Driving in pedestrian mode is possible when the platform is raised and the side protection guardrails are folded down.*
- *The double-throw safety switch is activated.*
- *Maximum speed in pedestrian mode is reduced to 6 km/h.*

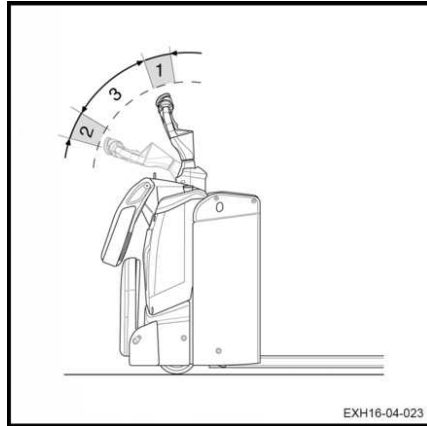

## Ride-on driving



### ⚠ WARNING

Risk of the operator falling

The side protection guardrails (5) prevent the operator from falling while driving.

Do not climb or sit on the side protection guardrails (5).

- Lower the platform (6).
- Raise the side protection guardrails (5).
- Lock the side protection guardrails in the raised position.
- Stand on the platform.

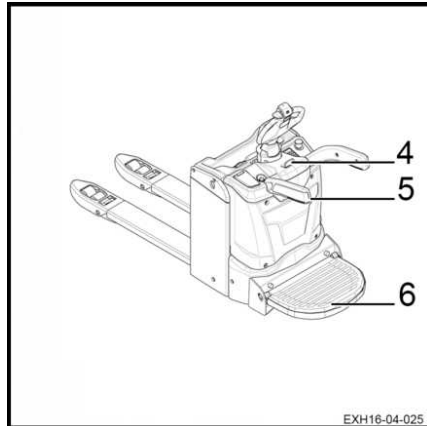



## Specific features of driving with folding platform trucks

- Tilt the tiller into the driving zone (3). The speed in ride on mode is limited to 10 km/h. ▷

In zones (1) and (2), the electromagnetic brake is applied. Then the truck cannot be driven.

### ⚠ DANGER

#### Risk of falling

Only one operator can stand on the platform at once. The truck is not designed to transport two people.

### i NOTE

*When the side protection guardrails are folded and the platform is in the lowered position, the speed of the truck is limited to 6 km/h.*

### ⚠ WARNING

Driving safety guidelines

It is prohibited for the operator to push loads sideways with the guardrails.

### i NOTE

*To lower the side protection guardrails (5), the tab (4) must be pressed to unlock them.*

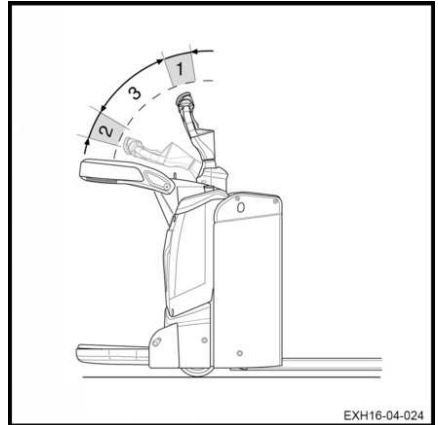

## Operating the FleetManager™ option

# Operating the FleetManager™ option

## Description of the FleetManager option

The FleetManager option allows you to control access to the truck. The option is a fleet management system.

You can access the system:

- Either by using a keypad
- Or by using a reading device for a transponder or an RFID card

The fleet manager sets the access details via the web interface. This affects the transponder cards or PIN codes for the corresponding trucks. It is possible to change the amount of time for which the access authorisation is valid.

Software is also available.

Additional options:

- Shock sensor
- Tools for wireless data management:
  - ▶ GSM<sup>(2)</sup>GPRS<sup>(1)</sup> module with antenna

The options available on the truck are:

- Access control
- Access control and shock sensor
- Access control and GPRS module
- Access control, shock sensor and GPRS module

<sup>(1)</sup> GPRS: General Packet Radio Service

<sup>(2)</sup> GSM: Global System for Mobile Communication

### Shock sensor

This sensor allows you to record the shocks received by the truck.

If the truck receives a shock, it is possible to configure a speed reduction.

The fleet manager is the only person who is able to change certain parameters.

### NOTE

*Replace the sensor if it is faulty.*

### GSMGPRS module

The module consists of a GSM modem and an antenna.

The module allows you to:

- Access truck information remotely
- Use geolocation

The data is stored on a server.

Data is transmitted by Bluetooth (default) or by GSM module (optional).

## Commissioning a truck equipped with the FleetManager™ option

### Commissioning a truck equipped with a keypad or an electronic key ▷

- Turn the switch key to start the truck.
- Enter the PIN code on the keypad. The PIN code consists of five to eight digits.

By default, no PIN code is given as a factory setting.

If the PIN code is correct, the LED (1) is not lit. The LED (2) flashes slowly at two-second intervals (green colour).

No acoustic signal sounds.

- Press the Enter key (3) to confirm.

The truck is now ready for use.

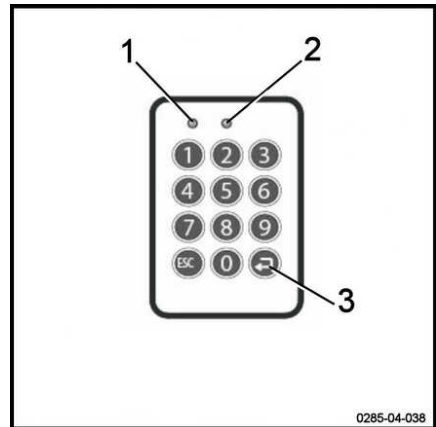

### NOTE

*In the configuration, the fleet manager can specify that the operator must enter a preliminary code when logging in. The operator can then assess the state of the truck.*

### Commissioning a truck equipped with an RFID reading device ▷

- Turn the switch key to start the truck.
- Place the RFID transponder card or the RFID transponder (4) in front of the reading device (3).

If the card is correct, the LED (1) is not lit. The LED (2) flashes slowly at two-second intervals (green colour).

Two acoustic signals sound.

The truck is now ready for use.

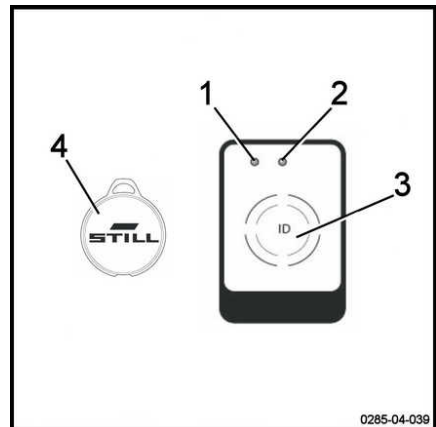

## Operating the FleetManager™ option

### FleetManager™ option: Colour code for the LEDs

The LEDs can have different statuses and different colours. Below is the list of the most common messages and their meanings.

Malfunction		Signal transmitter	Cause	Solution
LED status				
LED 1	LED 2			
Lit continuously Red colour	Off	A long acoustic signal sounds	<b>Reading device variant:</b> no valid access authorisation	Generate a valid access authorisation using the interface
			<b>Keypad variant:</b> no valid access authorisation for the PIN code entered	
			<b>Keypad variant:</b> PIN code entered incorrect or not confirmed using the Enter key	Re-enter the PIN code
Lit continuously Red colour	Flashes once Green colour	A long acoustic signal sounds	The operator has been granted access authorisation. But the period of validity has expired.	Use the interface to enter a new period of validity
			The date of the truck is incorrect	
Flashes quickly Yellow colour	Lit continuously Green colour		Memory is 80% full	Clear the memory
Flashes quickly Red colour	Flashes quickly Red colour	A long acoustic signal sounds upon activation	There are several possible causes: - Reading device or keypad not accessible - GPRS module not accessible - Built-in rechargeable battery flat - Memory full	Contact the After-Sales Service Centre

Malfunction		Signal transmitter	Cause	Solution
LED status				
LED 1	LED 2			
Flashes quickly Red colour	Lit continuously Green colour		A shock has occurred	Reset the shock
Flashes quickly Blue colour	Off		The truck is connected via a Bluetooth link. The operating data is being read. The reading process can take up to five minutes.	The truck is switched on but is not moving. Wait for all of the relevant data to be read. As soon as the LEDs change to a different status, resume work.

## Operating the FleetManager™ option

### Disconnecting a truck equipped with the FleetManager™ option

#### NOTE

*Operators must not log off intentionally while driving.*

#### WARNING

Access to the truck must be disabled.  
Unauthorised users are not allowed to use the truck.

### Disconnecting a truck equipped with a keypad or electronic key ▷

- Park the truck in a safe place.
- Press the button (3) to log off. Keep the button pressed in.

No LEDs light up. A long acoustic signal sounds.

The LED (1) lights up for a second (red colour). The LED (2) is not lit. A long acoustic signal sounds.

The LED (1) is no longer lit. The LED (2) flashes slowly at two-second intervals (green colour). No acoustic signal sounds.

The truck is disabled.

- Turn the switch key to the off position to switch the truck off completely.

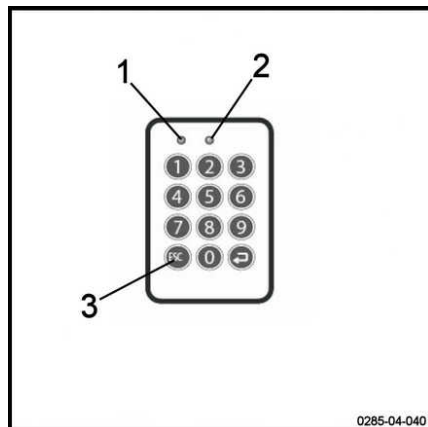

### Disconnecting a truck equipped with an RFID reading device ▷

- Park the truck in a safe place.
- Briefly place the RFID card or the RFID transponder (4) in front of the reading device (3).

The LED (1) lights up for a second (red colour). The LED (2) is not lit. A long acoustic signal sounds.

The LED (1) is no longer lit. The LED (2) flashes slowly at two-second intervals (green colour). No acoustic signal sounds.

The truck is disabled.

- Turn the switch key to the off position to switch the truck off completely.

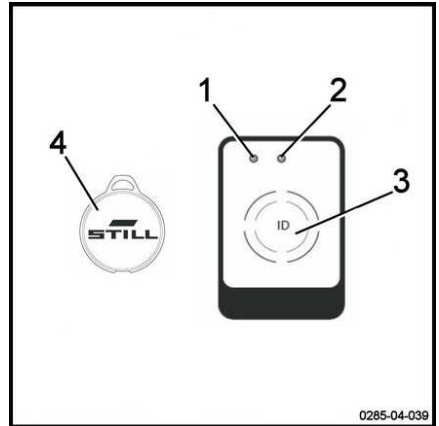

## Transporting loads

### Transporting loads

#### Load handling safety rules

##### **⚠ WARNING**

Closely follow the following instructions before picking up loads. Never touch or stand on moving parts of the truck (e.g. lifting device, pushing devices, work installations or devices for picking up loads).

##### **⚠ WARNING**

Take care not to trap hands or feet when operating the truck.

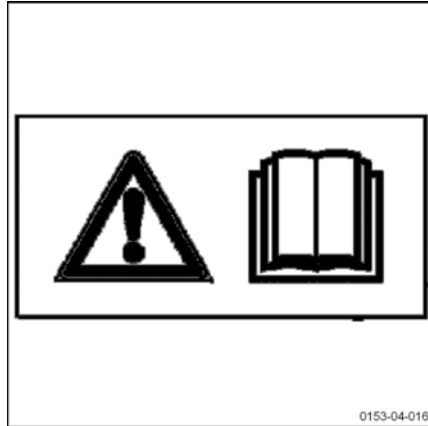

#### Grabbing a loading unit

Watch out for the following elements:

- the load must be well-balanced and centred correctly between the fork arms
- the fork arms must be sufficiently slid underneath the load to guarantee stability.

The load must not protrude too far over the fork arms, nor should the fork arms protrude too far out from the load.

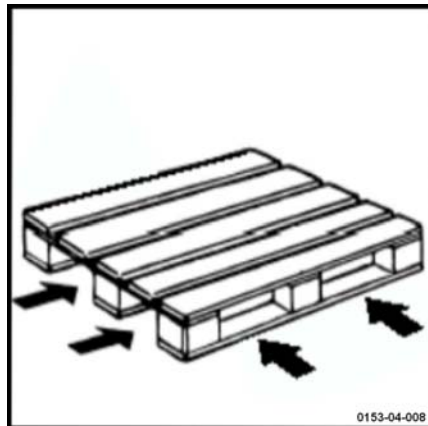



## Transporting pallets or other containers

As a general rule, loading units must be transported one by one (e.g. pallets). Transporting several loading units at a time is only authorised:

- when the safety preconditions are fulfilled.
- by order of the monitoring agent.

The forklift operator must ensure that the loading unit is properly packaged. He must only move loading units that have been carefully prepared and that meet the safety requirements.

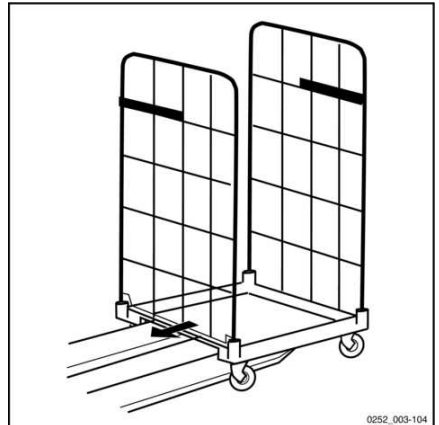
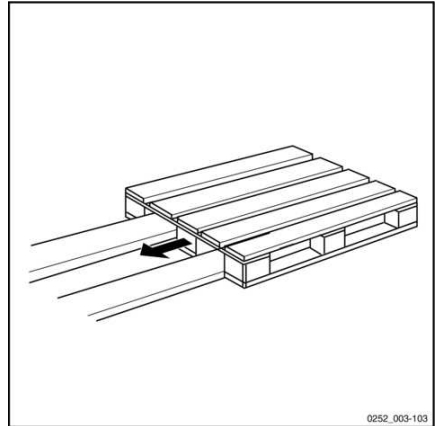

## Transporting loads

### Lifting and lowering the load arms



#### NOTE

*Keep your hands on the tiller when raising or lowering the load arms.*

#### Lifting the load arms:

- Press the lift control (1).

The load arms are raised.

#### Lowering the load arms:

- Press the lowering control (2).

The load arms are lowered.

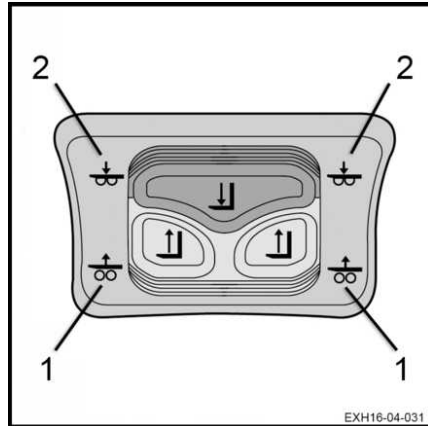

## Load handling

### ⚠ WARNING

Risk of crushing feet  
Safety shoes must be worn.

### ⚠ WARNING

Arrangement of loads

Do not touch nearby loads or loads positioned at the side or in front of the load being handled.

Arrange the loads with a small space between them to prevent them hooking onto one another.

### Before picking up a load

- Ensure that the load weight does not exceed the capacity of the truck.
- Also ensure that the load is stable and balanced to avoid dropping any part of the load.
- Check that the width of the load is compatible with the width of the load arms.
- Check that the load is not damaged.

#### **⚠ DANGER**

##### **Risk of tipping**

It is essential to slow down when approaching a corner or on wet ground.

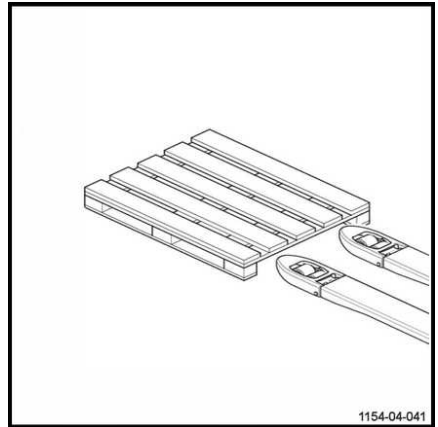

### Picking up a load from the ground

Proceed as follows:

- Approach the load carefully.
- Lower the load arms so that they can be easily inserted into the pallet.
- Insert the load arms under the load.
- For a load that is shorter than the load arms, position it so that the load overhangs the end of the load arms by a few centimetres. This will prevent the load hooking onto the one in front.
- Raise the load arms a few centimetres to lift the load.
- Withdraw the load slowly in a straight line.

## Transporting loads

### Transporting a load

Observe the following recommendations:

- Drive forwards for optimum visibility
- Travel up or down slopes with the load uphill. Do not travel across the slope or make a U-turn
- Reverse travel is used for setting down the load. Adjust your speed
- Do not drive with an unstable load
- If visibility is poor, let someone guide you
- Raise the forks slightly in order to pass obstacles
- Be careful of low passageways, low doorways, scaffolding, pipes etc.
- Check that the width of the load is not greater than the width of the aisle

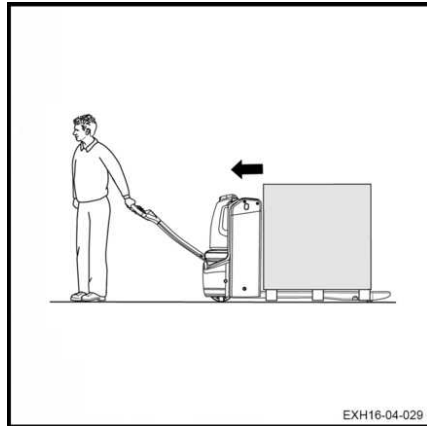

### Setting a load down on the ground

Proceed as follows:

- Drive the machine to the required location.
- Carefully move the load into the unloading area.
- Lower the load until the load arms are free.
- Withdraw the truck in a straight line.
- Raise the load arms again several centimetres.

#### CAUTION

Risk of accident

Before you set down the load, ensure that no one is around the truck or the load.

## Cold store usage (optional)



### ⚠ CAUTION

Standard trucks risk being subject to significant damage if used in extreme conditions.

Only trucks with the Cold Store option may be used inside cold storage. Specific oil designed for cold stores must be used.

These trucks are identified by their Cold Store label.

### Area of Use

Trucks with the Cold Store option may be used in two different areas:

- **operating range 1:** the truck can operate at a temperature of  $-5\text{ }^{\circ}\text{C}$  and, for short periods, at a temperature of  $-10\text{ }^{\circ}\text{C}$ . It must be parked outside of the cold store.
- **operating range 2 (Entry / Exit applications):** the truck must be used alternately inside and outside of the cold store. It can withstand temperatures between  $-30\text{ }^{\circ}\text{C}$  and  $+45\text{ }^{\circ}\text{C}$ . Specific rules should be followed so as not to damage the truck and to avoid the occurrence of streaming (see the following paragraph). The truck is parked outside of the cold store.

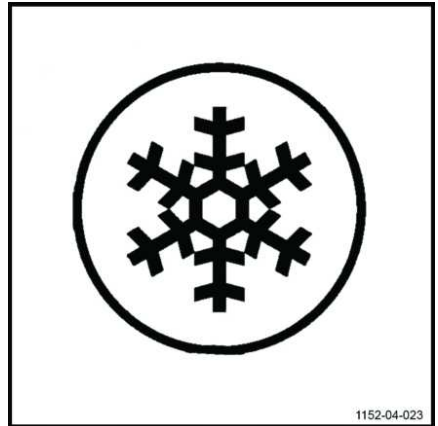

### Precautions for Use

The difference in temperature between the cold store and the room temperature zone may result in the formation of condensation water.

This water can freeze when the truck goes back into the cold store and jam the moving parts of the truck.

Streaming occurs if the truck remains outside of the cold store for more than ten minutes. Therefore, it is essential to leave the truck outside of the cold store for 30 minutes so that the condensation disappears.

### ⚠ DANGER

**If the condensation freezes in the cold store, it is prohibited to operate the jammed parts.**

This could cause permanent damage to the truck.

## Cold store usage (optional)

### Parking

The truck must be parked outside of the cold store.

Parking inside the cold store could cause serious damage to the electrical and mechanical equipment (seals, hoses, rubber and synthetic parts).

#### CAUTION

Do not leave discharged or unused batteries in the cold store.

They could be permanently damaged.

## Before leaving the truck

- Choose a safe and level location.
- Set down the load and fully lower the load arms.

The load arms must touch the ground.

- Switch off the truck.

The automatic braking is activated.

- Remove the switch key.

### **DANGER**

#### **Risk of injury!**

It is prohibited to park the truck with the load lift system in the raised position.

---

## Handling the battery

# Handling the battery

## Battery type

Trucks can be fitted with different types of battery. Comply with the information indicated on your battery's type plate, as well as with its features.

### WARNING

The weight and size of the battery influence the stability of the truck.

The new battery must weigh the same as the old one. Do not remove extra weight or change its position.

### CAUTION

Be careful not to damage any wiring when replacing the battery.

## Order picking

### Maintenance personnel

The battery must be replaced by specially trained personnel. Personnel must follow the manufacturer's instructions for the battery, the charger and the truck.

It is also necessary to follow the battery maintenance instructions.

### Fire protection measures



### WARNING

Do not smoke or create a flame when handling batteries. There must be no combustible material or tools that produce sparks within a minimum radius of 2 m around the truck and the battery charger.

The work area must be well ventilated. Fire extinguishers must be provided and located near the work area.



## Parking the truck securely

When the battery is being worked on, the truck must be parked safely. The truck can only be restarted when the covers and connectors have been put back in the operating position.

## Opening and closing the battery hood ▷

### Opening the battery hood

To open the battery hood:

- Immobilise the truck.
- Lower the load arms.
- Switch off the ignition (key or electronic key).
- Press the emergency off switch.
- Lift the hood (1) using the handle designed for this purpose.

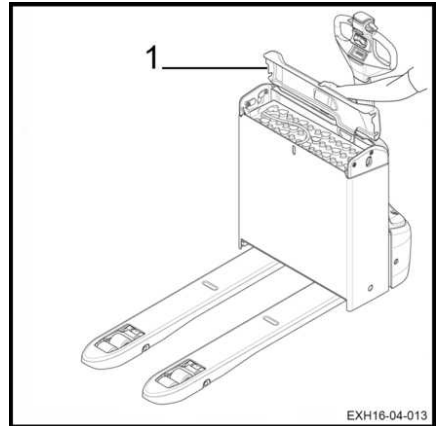

### Closing the battery hood

To close the battery hood:

- Close the hood (1).

#### **⚠ WARNING**

Risk of trapping fingers

When closing the battery hood, correctly position your fingers to avoid any risk of them being trapped.

- Ensure that the battery hood is closed securely.

#### **⚠ CAUTION**

Risk of sparks

Never drive with the hood open or incorrectly closed.

## Handling the battery

### Disconnecting/connecting the battery connector

#### **⚠ WARNING**

Major risk of arcing and destruction of contacts

Never connect or disconnect the connector if the truck is switched on.

Regularly check the condition of the contacts of the connectors. Replace them if there are signs of arcing and carbonisation.

Adhere to the direction of polarity "+" and "-". Always connect "+" to "+" and "-" to "-". Do not reverse the connectors.

Each ½ connector has a polarising pin. Ensure that the connectors are present and in good condition. They prevent any risk of reverse polarity.

#### Disconnecting the battery connector

- Immobilise the machine and switch off the ignition.

The fixed socket on the truck (1) is located above the battery and under the battery hood.

- Open the battery hood.
- Pull the handle of the battery connector (2) to disconnect it from the fixed socket (1) on the truck.

#### Connecting the battery connector

- Press the battery connector (2) into the fixed socket (1) on the truck.
- Close the battery hood.

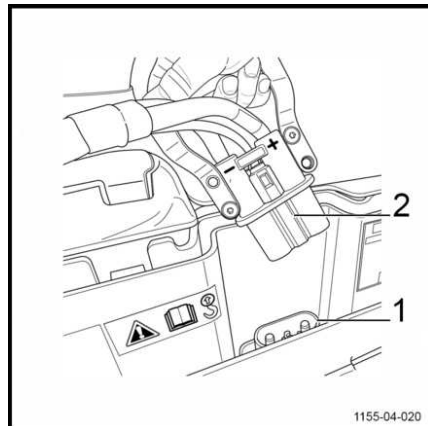

## Using the side socket to charge the lithium-ion battery

A side socket (1) can be installed on the battery on the side of the truck. The socket allows you to charge the battery without removing the lithium-ion battery connector of the truck.

### CAUTION

Risk of damage to the battery

It is essential not to switch off the lithium-ion battery during charging.

### CAUTION

Risk of damage to the battery

Do not connect two external chargers to charge the battery. The forklift operator must use either the side socket or the truck socket for charging.

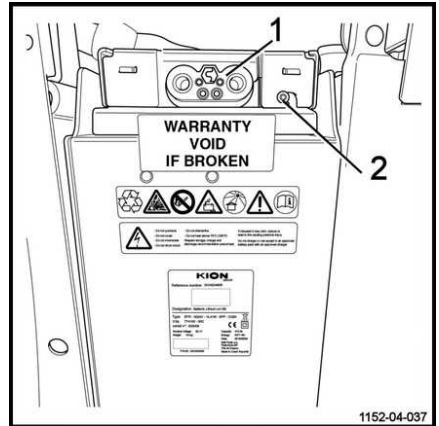

Proceed as follows:

- Park the truck close to the charging station.
- Immobilise the machine. Lower the fork arms.
- Switch off the ignition (key or electronic key).
- Disconnect any additional electrical systems before charging. Charging cuts off the electrical supply to the truck and to additional equipment.
- Switch the charger on as directed in the specific instructions for the charger. Charging of the battery is automatically managed by the on-board electronics of the battery.
- Plug the socket of the charging station into the side socket (1) located on the side of the truck.

A green LED (2) lights up. The LED indicates that the connector of the side socket (1) is correctly inserted and that charging is in progress.

### NOTE

*If the LED remains off, the connector is not detected. Please contact the After-Sales Service Centre.*

## Handling the battery

- When charging is complete and the charger has stopped, unplug the charger.



### NOTE

*It is possible to stop charging before the end of the complete cycle. The operator can resume work more quickly. It is advisable to recharge the battery after each use if possible. The battery charge percentage is indicated on the display screen. The charging time is indicated on the screen of the charger.*

- Switch on the ignition (key or electronic key) and check the charging status of the truck on the display.

The truck is now ready for use.

### CAUTION

Risk of damage to the side socket

The side socket is intended only for charging the battery.

If the socket is faulty, please contact the After-Sales Service Centre.

## Charging the battery using an external charger

### CAUTION

Electrical hazards

Make sure that the charger is compatible with the battery of the truck in terms of voltage and charging current (refer to the instructions for the charger).

For a gel battery, use a gel battery charger or an adjustable charger on the gel setting.

Ensure the correct "+" and "-" polarity when connecting the battery and charger connectors. Do not reverse the connectors.

Proceed as follows:

- Park the truck close to the charging station.
- Immobilise the machine. Lower the load arms.

- Press the emergency off switch (1).
- Switch off the ignition (2) (key or electronic key).
- Open the battery hood.
- Disconnect the battery connector from the fixed socket on the truck.
- Connect the battery connector to the charging station.
- Switch the charger on as directed in the specific instructions for the charger.
- When charging is complete and the charger has stopped, unplug the battery connector from the charger.
- Reconnect the battery connector into the fixed socket on the truck.
- Close the battery hood.
- Pull the emergency off switch (1).
- Switch on the ignition (2) and check the charging status of the truck on the display (3).

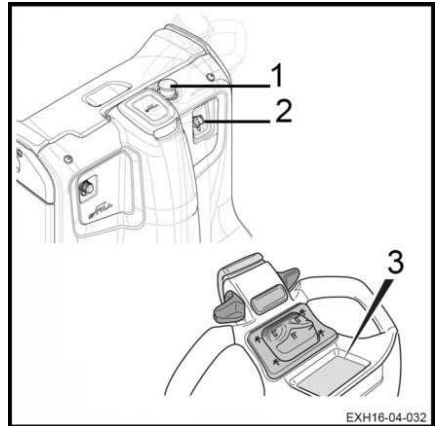

The truck is now ready for use.

#### **⚠ WARNING**

Risk of sparks

Always connect the battery connector before switching on the battery charger and disconnect the connector after switching off the charger.



#### **NOTE**

*The connectors are fitted with a keying pin. To avoid reversed connections, regularly check its presence and condition.*

#### **⚠ WARNING**

A battery produces explosive gases during charging. Make sure that the area is well-ventilated. Make sure that the battery hood remains open for the entire time the battery is charging.

## Handling the battery

### Using the on-board charger

Thanks to the on-board charger, it is no longer necessary to use a charging room. In fact, this charger can be connected to any 2P+T, 230-V, 16-A socket.

However, before charging in this way, it is necessary to ensure that the location selected for charging satisfies all of the following safety requirements:



#### NOTE

*The charger is compatible with wet lead batteries, gel lead batteries and lithium-ion batteries.*

The charger is designed:

- To be incorporated in the truck.
- To remain permanently connected to the battery.
- To stay connected to the mains during periods when the truck is not being used to ensure the availability of the machine.

#### CAUTION

Charging instructions

It is strictly prohibited to use an on-board charger other than the one recommended.

Do not disconnect the battery connector during charging (flashing green indicator or battery charging icon) except for the lithium-ion battery.

The truck cannot be operated during charging.

#### WARNING

A lead battery produces explosive gases during charging.

- Make sure that the area is well-ventilated.
- Make sure that the battery hood remains open for the entire time the battery is charging.

The on-board charger is intended to recharge the battery.

- Switch off the truck.
- Connect the charger plug to a mains wall socket. The charger plug (1) is located under the centre cover of the truck dashboard.

Charging starts automatically. A green indicator flashes or a battery charging icon is present on the truck display.

- Unplug from the mains wall socket when the battery is fully charged. It is also possible to stop the current charging by unplugging from the mains wall socket (for lithium-ion batteries only).
- Store the charger plug (1) in its compartment under the centre cover of the dashboard.

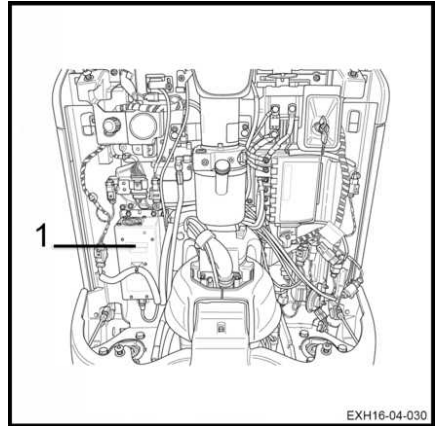

### ⚠ CAUTION

Risk of damage to the mains cable resulting in electric shock and/or burns!

Park the truck close to the mains wall socket. The mains cable of the on-board charger must not be taut when connected and charging.

The mains cable must be checked regularly as part of periodic statutory checks and maintenance operations.

## Adjusting the on-board charger



- When the truck is delivered with its battery, the charger (1) settings are adjusted in the factory.
- When the truck is delivered without a battery, the adjustment is made according to the configuration chosen during the order.

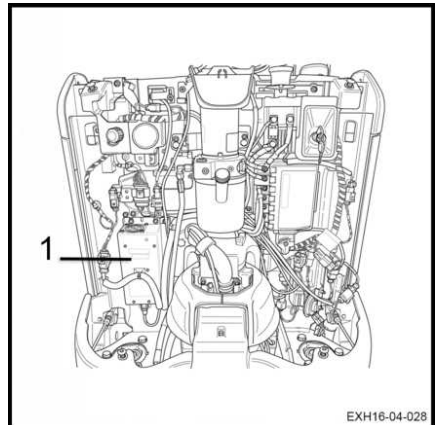

## Handling the battery

### General information on changing batteries

#### Removing/refitting the battery

When handling batteries, make sure that the capacity of the equipment used (hoist, slings, hooks, roller frame, trolley) is sufficient for the battery weight.

If you are installing a replacement battery, it must be identical to the original battery in terms of:

- Weight
- Compartment dimensions
- Voltage
- Capacity
- Socket

Refer to the rating plate of the truck for the minimum and maximum acceptable weights.

#### **⚠ CAUTION**

Risk of injury

The battery is a heavy and fragile component that must be handled with care.

It is recommended to wear gloves and safety shoes.

#### **⚠ CAUTION**

Risk of crushing.

When lowering the forks, make sure that your feet are not underneath the fork carriage.

#### **⚠ CAUTION**

Risk of trapping.

During operations to lock and insert the battery, keep your fingers away from moving parts to avoid any risk of them being trapped.

### Changing the vertical access battery

To change the battery, proceed as follows:

- Immobilise the truck.
- Lower the load arms.
- Switch off the ignition and remove the key.
- Press the emergency off switch.
- Open the battery hood.
- Disconnect the battery connector.



- Attach the slinging hooks to the battery compartment.

**NOTE**

*Using secured hooks is recommended.*

- Lift the battery.
- Replace the battery.
- Position the new battery in the chassis.
- Remove the sling hooks.
- Reconnect the battery connector.
- Close the battery hood.
- Return the truck to service.

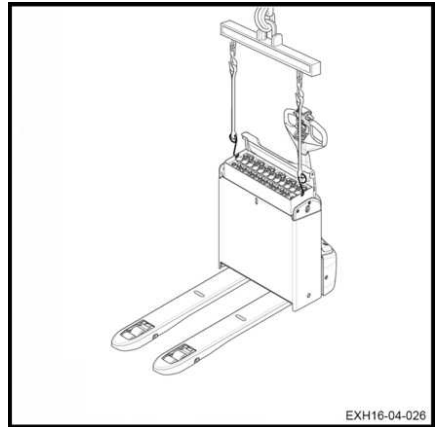

## Handling the battery

### Changing the battery on a truck equipped with a side-access battery

To remove the battery, we recommend that you use a fixed roller frame or a truck with extraction rollers (fitted with rollers) for easier handling of the battery.

- Immobilise the truck.
- Lower the forks.
- Switch off the ignition and remove the key.
- Press the emergency off switch.
- Open the battery hood.
- Position the truck with extraction rollers or the roller frame in the upright position next to the battery compartment on level ground.
- Disconnect the battery connector.
- Place the connector on the battery cells. ▷

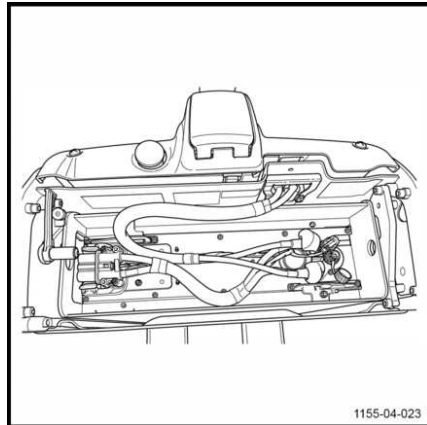

- Lift the locking pin (1) to unlock the battery. ▷

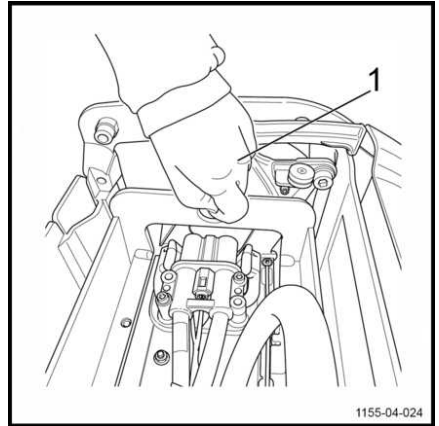

- Place the locking pin on the edge of the chassis as shown in the illustration (2). ▷

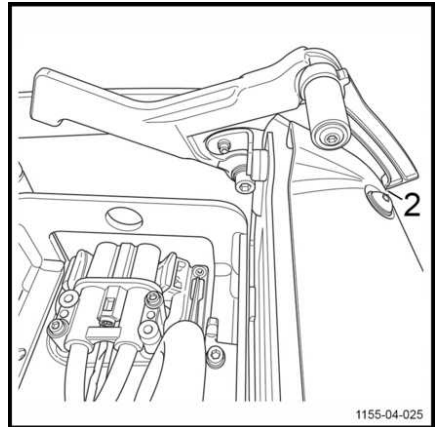

## Handling the battery

- Take hold of the battery (3).

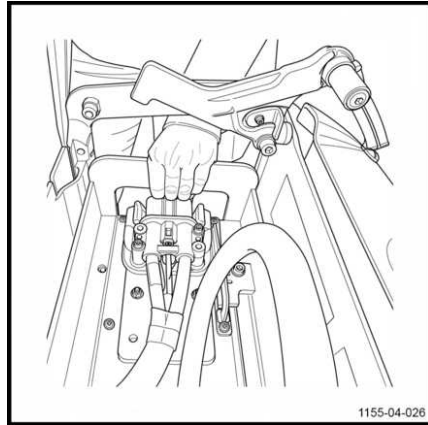

- Pull the battery (4) onto the roller frame to remove it from its compartment.
- Replace the battery and push it all the way into the compartment.

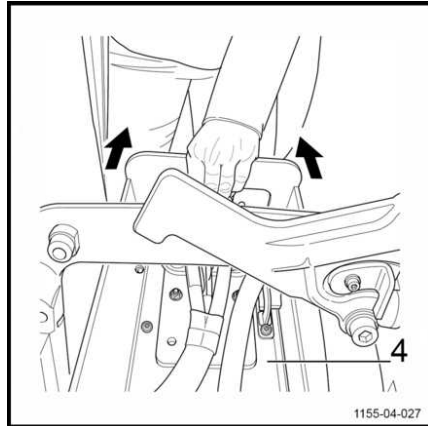

- Position the locking pin (1) in the opening (5) provided on the chassis. ▷
- Lower the locking pin (1) until you hear a small click.
- Reconnect the battery connector.
- Close the battery hood.
- Return the truck to service.

### ⚠ WARNING

Risk of losing the battery

Before restarting the truck, ensure that the battery is correctly installed and locked, and that the battery hood is fully locked.

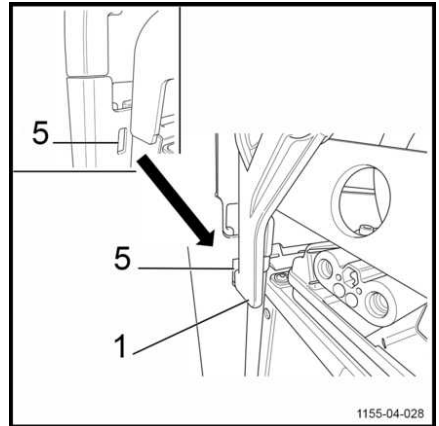

### Choice of opening side for battery compartment ▷

It is possible to remove the battery from its compartment to the left or right of the truck:

- Reverse the battery mounting assembly (6) on the chassis and the hood.

### **i** NOTE

*Regularly check that the battery mounting assembly is always correctly positioned on the truck.*

This operation should preferably be carried out by the After-Sales Service Centre. If the battery mounting assembly is incorrectly positioned on the chassis and the hood, the locking system of the battery cannot function correctly.

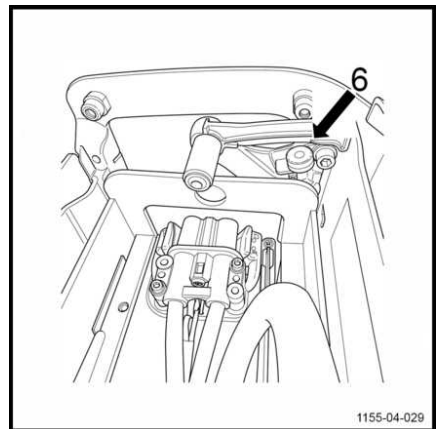

## Handling the truck in an emergency

# Handling the truck in an emergency

## Towing and transporting the truck

### Towing the truck

#### CAUTION

Risk of the equipment becoming worn or damaged  
The brake is applied if there is no power supply to the truck from the battery.

The truck must be moved with the front raised and with caution.

#### CAUTION

Risk of the equipment becoming worn or damaged  
Do not pull the truck by the tiller.

#### CAUTION

Risk of the equipment becoming worn or damaged  
Unload the truck before towing it.

### Transporting the machine

If the truck has to be transported, please ensure that it is properly chocked and protected against bad weather.

#### WARNING

Risk of truck losing stability

Exercise great care when moving a truck that has no battery and is equipped with reinforced stabilisers.

## Handling the truck in specific situations

### Slinging the truck

#### **⚠ DANGER**

##### **Danger of truck falling**

Only use slings and a hoist of sufficient quality. Check the weight of the machine (including battery) in order to choose a suitable device. Refer to the technical features.

Observe the following instructions:

- Shut off the truck and disconnect the battery.
- Lower the load arms (the initial lift must be in the lowered position).
- Remove any items that could fall.
- Protect all parts that come into contact with the lifting device.
- Hook the lifting device (1) onto the appropriate locations as shown by the "slinging hooks" label.

#### **i NOTE**

*Do not sling the truck by the tiller. Do not sling the truck by the accessory support.*

- Carefully lift the truck.

#### **⚠ DANGER**

##### **Risk of falling**

Make sure no one is under or near the truck when slinging the truck.

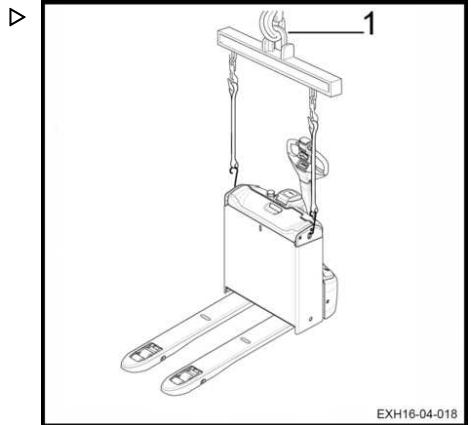

## Handling the truck in specific situations

### Lifting the truck

#### **⚠ DANGER**

##### **Danger of truck tipping over**

Truck lifting must be performed carefully.

For some work, it is necessary to lift the truck.

- Lift the load arms.
- Switch off the ignition and disconnect the battery connector.
- Use a jack with adequate lifting capacity.

##### **Front section of the truck:**

- Place the jack under the chassis (1).

##### **For work on the lifting device:**

- Position the jack under the battery frame (2).

##### **Maintenance of the load wheels:**

- To service the load wheels, position the jack under the load arms in the locations indicated (3).

As a safety precaution, always insert a wooden chock.

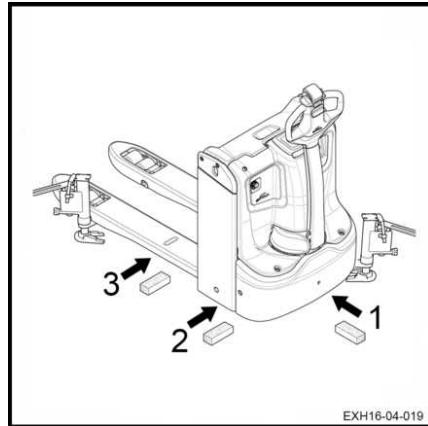

#### **⚠ WARNING**

Risk of truck falling

Immobilise and chock the truck after lifting it.

### Transporting the truck

#### **⚠ CAUTION**

Always switch off the ignition and disconnect the battery.

Never tie down or sling the truck by the control unit or other points not designed for this.

#### **⚠ CAUTION**

Risk of damage to the truck.

Use a hoist and woven **NON METALLIC** slings with an adequate lifting capacity. Refer to the load weight shown on the truck's capacity plate.

The lifting operations must be performed by qualified personnel.

Trucks are generally transported by road or by rail.



The truck must be suitably protected from the effects of the weather during transport and storage.

To load or unload the truck, use an inclined plane or a mobile ramp.

If the truck is out of service or if the battery has been removed, sling the truck. See **Chapter 4 Slinging the truck**.

## Transporting the machine

If the truck has to be transported, please ensure that it is properly chocked and protected against bad weather.

### WARNING

Risk of truck losing stability

Exercise great care when moving a truck that has no battery and is equipped with reinforced stabilisers.

## Transporting the truck in the lift

The truck must only be taken in lifts with an adequate loading capacity that are designed for this purpose, and for which authorisation has been received from the operator. Inside the lift, the truck must be immobilised so that no part is in contact with the wall of the lift cage.

## Driving on loading bridges

Before crossing a loading bridge, the operator must make sure it is properly attached and secured and its load capacity is sufficient. Cross the loading bridge slowly and carefully. The driver must be sure that the vehicle to be entered is secured sufficiently against movement

### DANGER

#### **Danger of death.**

Do not stand within the hoist's operating radius or below the lifted truck.

A minimum safety distance of 100 mm from the walls of the lift must always be observed.

Anyone transported with the truck must only enter the lift after the truck has been correctly immobilised and they must exit the lift first.

and that it can support the load of the forklift truck.

The lorry driver and lift truck operator must coordinate the departure time of the lorry.

## Handling the truck in specific situations

**5**

---

## **Maintenance**

## General maintenance information

# General maintenance information

## General

The following instructions contain all the information required for maintenance of your truck. Carry out the various maintenance work in compliance with the maintenance plan. This will ensure that your truck is reliable and in good working order and that the warranty remains valid.

### Maintenance plan

One of the display functions indicates the truck's hours of use. Refer to it and consult the truck's maintenance plan.

The maintenance plan is followed by advice to facilitate work.

Maintenance intervals must be reduced if the truck is used under harsh conditions (extreme heat or cold, large quantities of dust).

### Grade and quantity of lubricants and other consumables

Only lubricants and other consumables specified in these operating instructions are authorised for use in maintenance work.

Lubricants and other consumables required for truck maintenance are listed in the maintenance specifications table.

Never mix different grades of grease or oil. If it is absolutely necessary to change brands, make sure to flush thoroughly beforehand.

Before changing any filters or working on the hydraulic system, thoroughly clean the surface and the areas around the part.

All containers used to pour oil must be clean.

## Servicing and maintenance personnel training and qualification

Truck maintenance must only be carried out by qualified and authorised personnel.

The annual inspection for prevention of accidents at work must be carried out by a person qualified to do so. The person carrying out this inspection must provide their expertise and opinion without being influenced by economic factors or company internal issues. Safety is the only critical deciding factor.

The person responsible for carrying out the inspection must have sufficient knowledge and experience to be able to assess the condition of the truck and the efficiency of the protective installations in accordance with the technical regulations and principles established for checking industrial trucks.

## Battery maintenance staff

Batteries must only be recharged, maintained and changed by specially trained personnel. Personnel must follow the manufacturer's instructions of the battery, the battery charger and the truck.

It is essential to follow the battery maintenance instructions and the battery charger operating instructions.

## Maintenance operations that do not require special training

Simple maintenance operations such as checking the hydraulic fluid level or checking the battery electrolyte level can be carried out by persons with no special training.

A specific qualification is not necessary.

Refer to the maintenance section of this manual for further information.

## Ordering spare parts and consumables

Spare parts are provided by our spare parts service department. You will find the information required to place an order in the spare parts and fitting catalogue.

Only use spare parts recommended by the manufacturer.

Unauthorised spare parts may increase the risk of accidents due to faults relating to quality or incorrect choices. Anyone who uses non-compliant spare parts must assume full responsibility in the event of an accident.

## Safety guidelines for maintenance

### Safety guidelines for maintenance

#### Servicing and maintenance measures

To avoid accidents during servicing and maintenance operations, take all necessary safety measures. For example:

- Ensure that there is no risk of the truck moving or starting up unexpectedly. For this reason, remove the battery connector.

#### Working on the electrical equipment

Operations on the truck's electrical system must only be carried out when there is no voltage supply.

Operating checks, testing and adjustment work on parts supplied with voltage must only be carried out by personnel:

- who have received detailed instructions
- who have been authorised to perform this work
- who have taken the necessary precautionary measures.

Rings, metal bracelets etc., must be removed before carrying out any operations on electric components.

Remove the electric equipment (which comprises electric components such as the traction controller) before carrying out any welding operations. This precaution prevents this electric equipment from being damaged.

Operations on the electric system require the consent of the manufacturer.

#### Safety devices

After any repair or maintenance work, it is necessary:

- to refit all safety devices

- to check these for correct operation.

## Easily accessing the technical compartment ▷

In order to perform maintenance on various truck components, it is necessary to access the technical compartment.

- Switch off the ignition (switch key or electronic key).
- Press the emergency off switch.
- Open the battery compartment.
- Disconnect the battery connector.
- Remove the four mounting screws (1) on the front cover.
- Lift the cover and remove it.

The technical compartment can be accessed. After the operation, the cover must be repositioned.

- Put the front hood in position.
- Tighten the four mounting screws (1).
- Reconnect the battery connector.
- Return the truck to service.

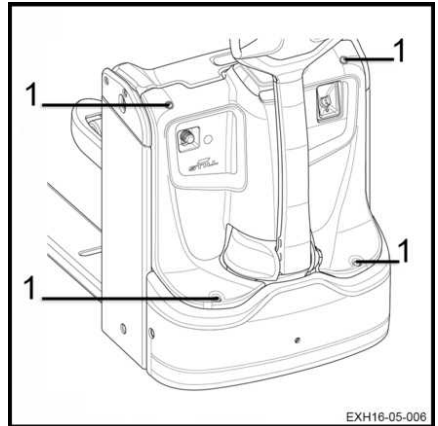

## Technical data for inspection and maintenance

## Technical data for inspection and maintenance

Assembly	Consumables/lubricants	Capacities/adjustment values
Hydraulic system	Hydraulic oil	0.45 litres (minimum volume: 0.35 litres)
Transmission gear	Transmission gear oil	0.8 litres
Traction motor 1.1 kW for EXH 14, 1.3 kW for EXH 16, EXH-L 16, EXH-SF 16C, EXH 18, EXH 20, EXH 20+, EXH-L 20 and EXH- SF 20C	Fuse 1F1	Power: 300 A, quantity: 1
Pump motor 1 kW for EXH 14, EXH 16 and EXH 18 1.2 kW for EXH-L 16, EXH-SF 16C, EXH 20, EXH 20+, EXH-L 20 and EXH-SF 20C	Fuse 1F1	Power: 300 A, quantity: 1
Control fuse	Fuse 1F3	Control: 7.5 A, quantity: 1
Control fuse	Fuse 1F4	Control: 5 A, quantity: 1
Battery	Distilled water	As required
Joints	Lithium soap grease	As required



## Recommended lubricants

### DANGER

#### Toxic products.

Oils and other consumables are toxic products. It is advisable to handle and use them with the utmost care.

### Hydraulic oil

#### Recommended oil for standard use:

ISO-L-HM 46 as per ISO 6743-4 or ISO VG46-HLP as per DIN 51524-2

#### Recommended oil for heavy-duty use:

ISO-L-HM 68 as per ISO 6743-4 or ISO VG68-HLP as per DIN 51524-2

#### Recommended oil for the cold store version:

ISO-L-HM 32 as per ISO 6743-4 or ISO VG32-HLP as per DIN 51524-2



#### NOTE

*If in doubt, please ask your local dealer for advice. You should also consult your local dealer if a representative of an oil company offers you an oil product that is not specified in these operating instructions. Only the oils listed above are approved by the manufacturer. Using oil mixtures or hydraulic fluids that are not recommended can cause damage that may be expensive to rectify.*

### Transmission gear oil

#### Recommended oil:

Fuchs Titan Supergear 80W90 API GL4/GL5

### Aerosol can for chains

Standard chain spray.

### Multi-purpose grease

Lithium soap grease, extreme pressure with anti-wear additive - Standard DIN 51825 - KPF 2K - 30, KPF 2K - 20, KPF 2N - 30.



#### ENVIRONMENT NOTE

*Used oil must be stored safely until it is disposed of in compliance with environmental protection measures. No one should have access to the used oil. Do not dispose of used oil in drains or allow it to penetrate soil.*



#### ENVIRONMENT NOTE

*Do not allow the product to disperse into the environment. Packaging that has contained this product is treated as waste. Contaminated packaging must be completely emptied and may then be recovered following a thorough clean.*

## 1000-hour service plan

## 1000-hour service plan

Depending on the application, environmental conditions and driving style, the following procedures should be carried out every 1000, 2000, 4000, 5000, 7000 and 8000 hours

**Preparation**

- Clean the truck
- Check the error codes using the diagnostic tool
- Check the time and date on the display
- Enter the next service interval

**Chassis, bodywork and fittings**

- Check that the battery is correctly secured in the battery compartment
- Check the lock for side access battery replacement
- Check the roller frames for side access battery replacement
- Check the side guide rollers
- Check the linkage and joints

**Steering and wheels**

- Grease the axles and the bearing of the wheels (lubricated version)
- Check the wheels for damage, foreign bodies and wear
- Check the drive wheel for wear
- Visually check the mounting of the tiller
- Visually check the tiller and of the mounting of the steering centre

**Truck**

- Check the operation of the parking brake
- Check the brake for wear

**Electrical equipment**

- Check the battery acid level and the electrolyte level
- Check the condition of the cables and the battery sockets and ensure that they are positioned correctly
- Clean the on-board charger
- Check the operation of the on-board charger
- Check the condition, the routing and the mounting of the electrical connections
- Clean the electrical components

**Hydraulic system**

- Check the height adjustment of the mechanical stabilisers
- Visually check the mechanical stabilisers for wear
- Check the mounting of the pump-motor unit
- Check the hydraulic system oil level
- Check the hydraulic system for leaks

**Load lift system**

- Check the height sensors (on lift mast)

Clean the lifting function sensors (if fitted)
Check the mobile chassis
Check the linkage of the initial lift
Check the initial lift sensors
Adjust the clearance of the sliding pads on the guide rollers of the initial lift
Check the pins and the mounting of the push rods

## 3000-hour maintenance plan

Depending on the application, environmental conditions and driving style, the following procedures should be carried out every 3000, 6000 and 9000 hours
<b>Note</b>
Carry out all 1000-hour maintenance work
<b>Hydraulics</b>
Drain the hydraulic oil
Hydraulic system: clean and replace (if necessary) the pressure filter
Hydraulic system: clean and replace (if necessary) the breather
Hydraulic system: clean and replace (if necessary) the suction filter

## 10,000-hour service plan

Depending on the application, environmental conditions and driving style, the following procedures should be carried out every 10,000 hours
<b>Note</b>
Carry out all 1000-hour maintenance work
Carry out all 3000-hour maintenance work
<b>Motor</b>
Drain the transmission gear oil

## Chassis, bodywork and fittings

## Chassis, bodywork and fittings

## Cleaning the truck

Disconnect the battery before cleaning the truck.

Be very careful using steam jets or cleaning products with a strong degreasing effect. They dilute the grease inside the sealed-for-life bearings. Relubrication is then impossible.

These cleaning methods damage the bearings.

**⚠ WARNING**

Use of compressed air

It is advisable to wear protection goggles and a mask.

If using compressed air, first remove stubborn dirt with a cold cleaning agent.

Before carrying out lubrication operations, thoroughly clean:

- The oil filling openings and the areas around them
- The grease nipples

Dry the truck after cleaning.

If, despite taking all of these precautions, water enters the motors, the truck must be returned to service. This operation prevents rust forming (it dries out by its own heat). The motors can also be dried using compressed air.



**NOTE**

*A truck that is cleaned frequently will also require more frequent lubrication.*

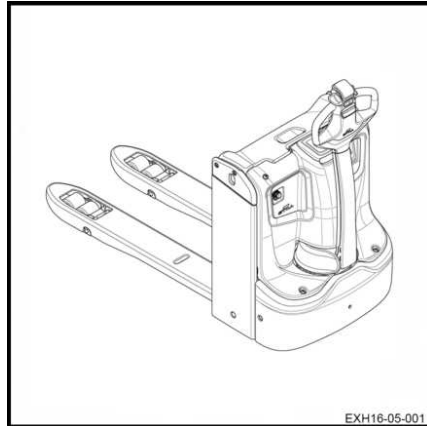

## General information on battery maintenance

### DANGER

#### Risk of injury

Before carrying out any operations on the electric installation, turn the truck power supply off. Disconnect the battery connector.

### Precautions to be taken during battery maintenance

The plugs on the battery cells must always be dry and clean.

Neutralise any spilt battery acid immediately.

The battery terminals and lugs must be clean, lightly covered with grease for terminals and securely tightened.

### Charging the battery

During the charging process, the surface of the battery cells must be clear to ensure sufficient ventilation.

Do not place metal objects on the battery.

The battery cover must remain open during charging. See the chapter entitled **Battery charging using an external charger**.

### Battery type

Lead or gel batteries are used. It is advisable to choose a compatible charger.

Before charging, ensure that the charger is suitable for the type of battery.

### CAUTION

Gel batteries are subject to specific charging, maintenance and treatment instructions. A non-compatible charger may result in a battery failure.

Observe the manufacturer's recommendations.



### NOTE

- *The discharge indicators used to check the battery must also be suitable for the type of battery*
- *Contact the relevant After-Sales Service Centre*

### Charging the battery

- Park the truck in an area without condensation or pollution and with sufficient ventilation.
- Stop the truck.
- Press the emergency off switch.
- Open the battery hood.
- Follow the instructions.

### CAUTION

Do not expose the charger to water, rain, oils, grease or any similar substances.

The charger becomes hot during the operation.

### CAUTION

Risk of injury

Do not obstruct the ventilation. Allow the charger to cool down for 10 minutes after charging is complete before touching it. Do not use the charger out of the truck.

## Chassis, bodywork and fittings

## Checking the condition of the load arms



- Check that the load arms (1) show no signs of deformation, splits, heavy wear or cracks.

**⚠ CAUTION**

Truck damage

If the carriage is damaged, have it changed by the After-Sales Service Centre.

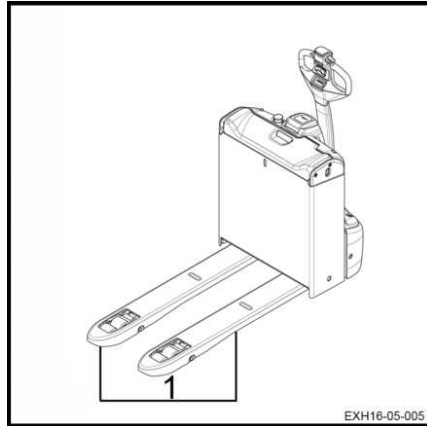

## Transmission

### Cleaning the traction motor cooling fins ▷

The traction motor is difficult to access.

- Immobilise the truck.
- Lower the forks.
- Switch off the ignition and remove the key.
- Press the emergency off switch.
- Open the battery hood.
- Disconnect the battery connector.
- Open the technical compartment front cover.
- Blow the motor (1) with compressed air.

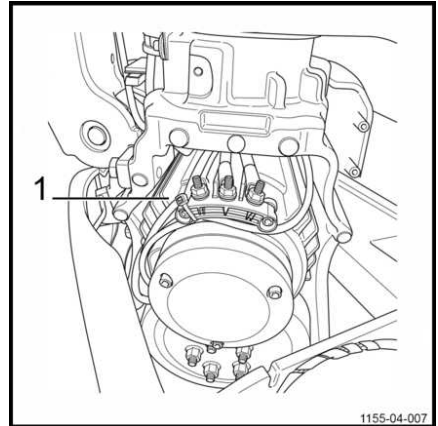

#### **⚠ WARNING**

It is advisable to wear protection goggles and a mask.

- Check that there are no signs of heat build-up in the connections of the power cables.
- Refit the technical compartment front cover.
- Reconnect the battery connector.
- Return the truck to service.

## Steering and wheels

## Steering and wheels

## Checking the condition of the wheels

- Raise the truck until the wheels are off the ground.
- Check that the wheels rotate freely and remove any objects that may prevent them from turning or may obstruct them.

**⚠ CAUTION**

Risk of damaging the wheels

In order to avoid any risk of damaging the wheel bearings and tyres, any wires or plastic strips that may wind around the wheel hubs and mountings must be removed.

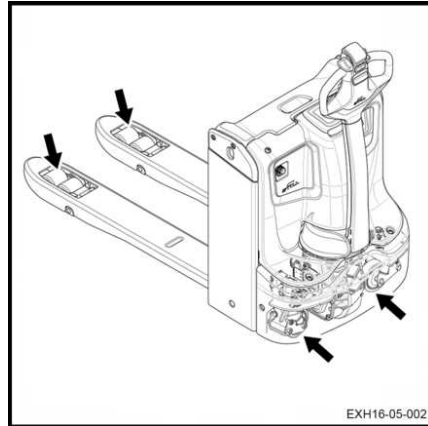

## Stabiliser maintenance

Trucks are equipped with two stabilisers. They ensure the dynamic stability of the truck. Different types of stabilisers are available as options.

Stabilisers do not require any specific maintenance or adjustment work. Wheel wear (drive wheel and stabiliser wheel) is automatically compensated.

However, it is necessary to check the condition of the stabilisers:

- No significant damage to the superstructure.
- The damper cylinder pins must not be twisted.
- No oil leakage must be present on the damper cylinder. This cylinder must be inside the spiral spring.
- No damage to the rollers. The wheels must rotate freely
- No locking at the level of the upper bearing.

- Ensure that the wheel nuts are correctly tightened.
- Ensure that there is no oil leakage under the truck when it is fitted with hydraulic stabilisers.

**⚠ WARNING**

Risk of loss of dynamic stability

The dynamic behaviour of the device must be monitored, particularly when turning. The behaviour of the truck must be the same when cornering, whether turning to the left or right. If there is a difference in behaviour, please contact the After-Sales Service Centre. Only the technician can replace the two stabilisers if deemed necessary.

**NOTE**

*It is necessary to monitor the wear of the wheels in order to preserve the traction of the truck.*



## Electrical equipment

### Cleaning and blowing air through the electrical components

#### ⚠ CAUTION

Electrical hazards

Always disconnect the battery connector before working on an electrical component.

- Press the emergency off switch.
- Disconnect the battery connector.
- Open the technical compartment.
- Blow the electrical components with compressed air.

#### ⚠ WARNING

Use of compressed air

It is advisable to wear protection goggles and a mask.

- Check the condition of the pin contacts of the harness connectors.

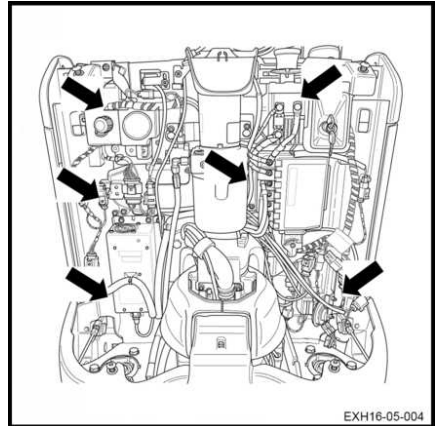

## Electrical equipment

## Checking the battery acid level and electrolyte density ▷

**⚠ WARNING**

The electrolyte (diluted sulphuric acid) is poisonous and caustic!

- Always wear suitable protective equipment (industrial goggles, safety gloves) when working on a battery.
  - Never wear a watch or jewellery when handling battery acid.
  - Do not allow any acid to get onto the clothing or skin or into the eyes. If this does happen, rinse immediately with plenty of clean water.
  - Immediately rinse away any spilled battery acid with plenty of water.
  - In case of injury, seek medical advice immediately.
  - Always follow the safety information provided by the battery manufacturer.
  - Comply with the regulations in force.
- 
- Check the battery acid level and electrolyte density according to the battery manufacturer's recommendations.
  - The cell covers of the battery must be kept dry and clean.
  - Any spillage of battery acid must be neutralised immediately.

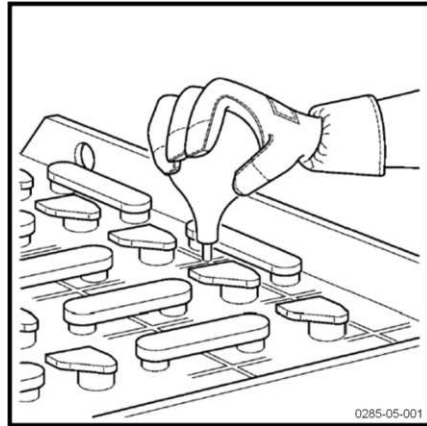
**ENVIRONMENT NOTE**

*Dispose of any used battery acid in accordance with the regulations.*

## Checking the condition of cables, terminals and the battery connector

- Check that the cable insulation is undamaged.
- Check that there are no signs of heat build-up in the connections.
- Check that the "+" and "-" output terminals are not sulphated (presence of white salt).
- Check the condition of the battery connector contacts and the presence of the keying pin.

### **⚠ CAUTION**

Risk of damaging the equipment

The points mentioned above can cause serious incidents. In the event of an incident, contact our After-Sales Service Centre as quickly as possible.

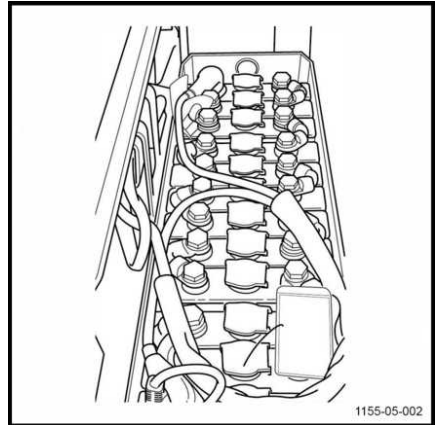

## Hydraulic systems

## Hydraulic systems

## Checking the hydraulic system for leaks ▷

- Switch off the truck and disconnect the battery connector.
- Remove the hood of the technical compartment.
- Inspect the hydraulic system: pipes, hoses and connections between the pump unit and the cylinders.
- Check cylinders for leaks.
- Check that the hoses are attached correctly and show no signs of friction wear.
- Check the external pipes and hoses on the technical compartment.
- Refit the hood of the technical compartment.
- Return the truck to service.

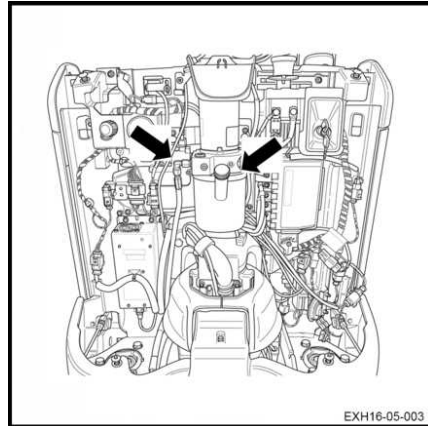
**⚠ CAUTION**

Risk of damaging the truck

In the event of leakage, please contact the After-Sales Service Centre.

## Checking the hydraulic oil level

To check the hydraulic oil level, proceed as follows:

- Immobilise the truck.
- Lower the load arms.
- Switch off the ignition and remove the key.
- Press the emergency off switch.
- Disconnect the battery connector.

- Remove the hood of the technical compartment. ▷

To ensure correct operation of the truck functions, the oil level must be between the minimum mark (3) and maximum mark (2) on the tank.

- Remove the plug (1). If necessary, top up via the opening.
- Refit the plug (1) afterwards.

### ⚠ CAUTION

Risk of damage to hydraulic components

Only use hydraulic oil that complies with the manufacturer's specifications (see table of recommended lubricants).

- Refit the hood of the technical compartment.
- Reconnect the battery connector.
- Return the truck to service.

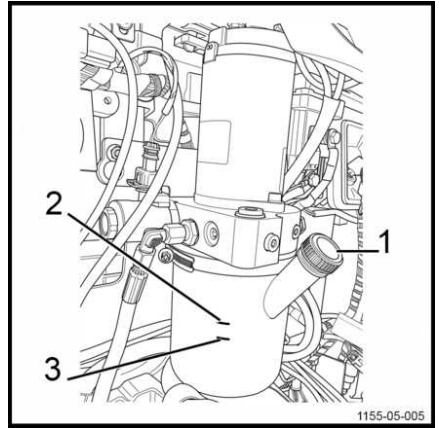

## Storage and decommissioning

# Storage and decommissioning

## Storage of truck

Precautions should be taken if the truck must not be used for a reasonably long period. The operations depend on the length of time it is unused.

### Long-term truck storage

The following work must be carried out on the truck to prevent corrosion if it needs to be stored for a long period of time. If the truck is to be stored for more than two months, it must be positioned in a clean and dry area. The area must be well-ventilated with no risk of freezing.

The following operations must be performed:

- Clean the truck thoroughly.
- Check the hydraulic oil level and refill if necessary.
- Lower the forks onto a suitable support (e.g. a pallet) until the chains are slack.
- Coat any unpainted metal parts with a thin layer of oil or grease.
- Grease all hinges and joints.
- Check battery condition and electrolyte density. Maintain the battery in accordance with the manufacturer's requirements. (Follow the instructions).
- Spray contacts with an aerosol product designed for contacts.
- Raise and chock the truck: the wheels must not touch the ground in order to prevent irreversible deformation of the tyres.
- Cover the truck with a cotton cover to protect it from dust.

### CAUTION

We recommend that you do not use a plastic sheet as this encourages condensation to form.

Consult the service department for further measures to take if the truck must be stored for a longer period of time.

### Recommissioning after storage

If the truck has been stored for more than six months, it must be checked carefully before being recommissioned. This check is similar to the workplace accident prevention inspection. It is therefore necessary to check all points and systems that are important for truck safety.

Carry out the following operations:

- Clean the truck thoroughly.
- Grease all hinges and joints.
- Check the condition and density of electrolyte, and, if necessary, recharge the battery.
- Check that there are no traces of condensation water in the hydraulic oil. Drain if necessary.
- Carry out the same maintenance work as for the first time it was commissioned.
- Commission the truck.
- In particular, check the following during start-up:
  - traction, control and steering.
  - brakes (service brake and parking brake).
  - lifting device.

## Permanent Putting Out of Commission (Destruction)

When scrapping the truck, it is necessary to:

- Remove the various parts of the truck (covers, battery, chains, motors etc.)
- Sort out the components depending on their type: pipes, rubber components, lubricants, aluminium, iron etc.
- Before scrapping the truck, notify the competent authorities of your country in writing.
- After receiving the authorisation from the competent authorities, remove any components according to national standards.



### NOTE

The client is solely responsible for any irregularities he has committed during or after the scrapping of the truck's components and the removal of components.

Storage and decommissioning



**6**

---

## **Technical specifications**

## Datasheet for the EXH14 model

## Datasheet for the EXH14 model

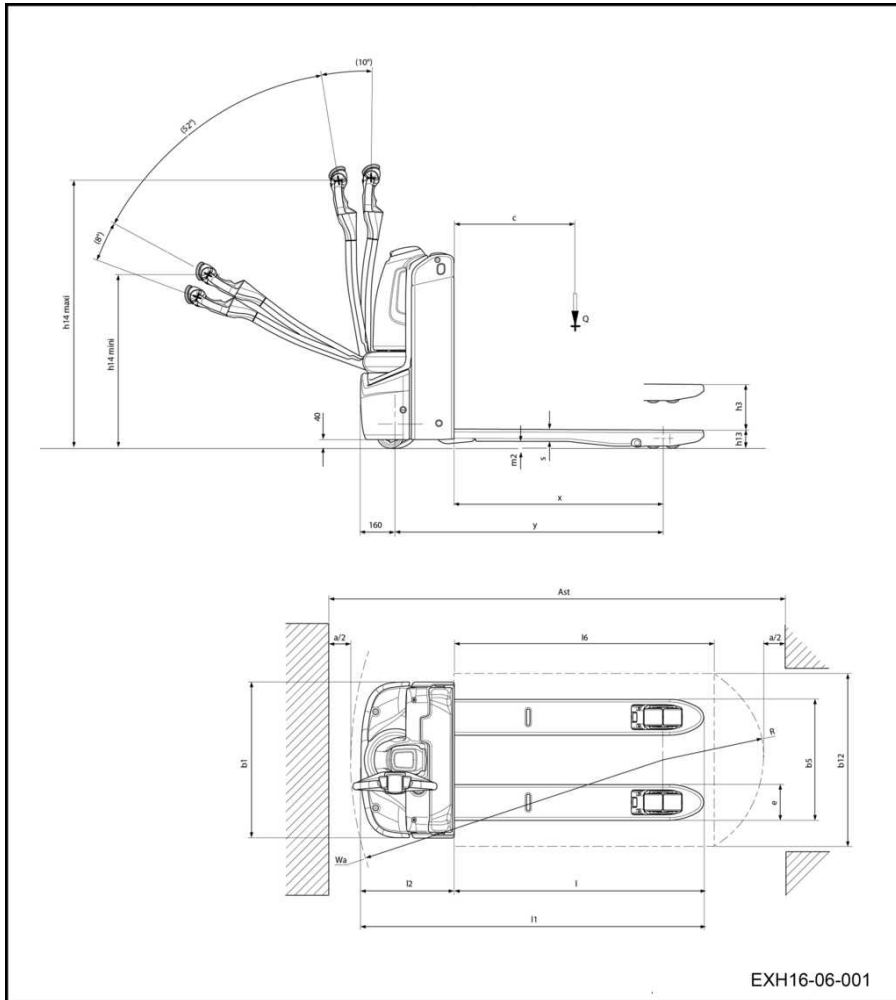

DESCRIPTION			
1.1	Manufacturer		Still
1.2	Model type		EXH14
1.3	Drive type: battery, diesel, petrol, LPG, mains power		Battery
1.4	Driving mode: manual, pedestrian, standing, seated, order picking		Standing/ pedestrian
1.5	Nominal capacity	Q (kg)	1400
1.6	Centre of gravity	C (mm)	600
1.8	Distance from load wheel axle to load support face ( $\pm 5$ mm)	X	893
1.9	Wheelbase ( $\pm 5$ mm)	Y	1160/1232

WEIGHT			EXH14
2.1	Kerb weight ( $\pm 10\%$ ) with battery	kg	329
2.2	Load per laden axle, drive side/load side ( $\pm 10\%$ ), load = 2000 kg	kg	609/1120
2.3	Load per unladen axle, drive side/load side ( $\pm 10\%$ )	kg	256/73

WHEELS				EXH14
3.1	Tyre: polyurethane, rubber, drive side/load side			Polyur- ethane
3.2	Drive wheel dimensions (width at the ground)	$\varnothing \times W$ (mm)		$\varnothing 230 \times 175$
3.3	Dimensions of wheels, load side <sup>(4)</sup>	$\varnothing \times W$ (mm)		$\varnothing 85 \times W85$ (bogies: $\varnothing 85 \times W80$ )
3.4	Additional wheels (dimensions)	$\varnothing \times W$ (mm)		2 x $\varnothing 125 \times$ W40
3.5	Number of wheels at drive side/load side (x = drive wheel) <sup>(4)</sup>			1X + 2/2 (1X + 2/4)
3.6	Track width, drive side ( $\pm 5$ mm)	mm		482
3.7	Track width, load side ( $\pm 5$ mm)	mm	52/54/56/68	355/375/395 /515

DIMENSIONS			EXH14
4.4	Lift ( $\pm 5$ mm)	h3 (mm)	125
4.9	Height of tiller in driving position minimum/maximum ( $\pm 5$ mm)	h14 (mm)	810/1205
4.15	Height at fork ends in the lowered position (0/+5 mm)	h13 (mm)	86
4.19	Total length (+5 mm)	L1 (mm)	1579
4.20	Length to the load mating face ( $\pm 5$ mm)	L2 (mm)	429

## Datasheet for the EXH14 model

4.21	Total width (±5 mm)	b1 (mm)	720
4.22	Load arm dimensions	s/e/L (mm)	55/165/1150
4.25	External clearance of the fork arms (± 5 mm)	s/e/L (mm)	520/540/560 /680
4.32	Ground clearance, at the centre of the wheelbase (±2 mm) <sup>(5)</sup>	m2 (mm)	32
4.33	Load dimension b12 x L6	b12 x L6	800 x 1200
4.34	Aisle width with predetermined load <sup>(2)</sup> <sup>(3)</sup>	Ast (mm)	2069
4.34. 2	Aisle width with a pallet 800 x 1200 crosswise <sup>(3)</sup>	Ast (mm)	2165
4.35	Turning radius (minimum) Initial lift, raised/lowered <sup>(1)</sup>	Wa (mm)	1365/1437

PERFORMANCE DATA			EXH14
5.1	Travel speed, laden/unladen (±5%)	km/h	6 / 6
5.2	Lifting speed, laden/unladen (±10%)	m/s	0.035/0.047
5.3	Lowering speed, laden/unladen (±10%)	m/s	0.064/0.027
5.8	Maximum gradient, laden/unladen	%	13/20
5.9	Acceleration time (10 m), laden/unladen	s	7/6.6
5.10	Service brake		electromagnetic

DRIVE SYSTEM			EXH14
6.1	Traction motor, hourly output	kW	1.1
6.2	Lift motor at 15% utilisation	kW	1
6.4	Battery voltage and capacity (discharge in 5 hours)	V/Ah	Gel/lead battery 24/62 or 125
6.5	Battery weight (±10%)	(kg)	Gel/lead battery 22
6.6	Energy consumption according to standardised VDI cycle	kWh/h	0.272
6.62	CO2 equivalent emission for electricity grid energy	kg/h	0.147
6.7	Turnover output	T/h	77
6.8	Energy consumption at turnover output	kWh/h	129

MISCELLANEOUS			EXH14
8.1	Speed monitor (AC controller)		KWPC
10.7	Noise level at forklift operator's ears (±2.5)	dB (A)	57

1) Forks raised/lowered

- 2)  $A_{st} = W_a + R + \text{Safety distance } a$ :  
 $a=200 \text{ mm}$
- 3) With Creep Speed option. Tiller in vertical position.
- 4) With bogies in brackets
- 5) Minimum/maximum



DESCRIPTION						
1.1	Manufacturer			Still		
1.2	Model type			EXH16	EXH18	EXH20 / EXH20+
1.3	Drive type: battery, diesel, petrol, LPG, mains power			Battery		
1.4	Driving mode: manual, pedestrian, standing, seated, order picking			Standing/pedestrian		
1.5	Nominal capacity	Q (kg)		1600	1800	2000
1.6	Centre of gravity	C (mm)		600		
1.8	Distance from load wheel axle to load support face (±5 mm)	X		893/965		
1.9	Wheelbase (±5 mm)	Y	Comp-act	1160/1232	-	-
			BS	1230/1302		-
			2 PzS	1300 / 1372		

WEIGHT				EXH16	EXH18	EXH20 / EXH20+
2.1	Kerb weight (±10%) with battery	kg	Compact	329	-	-
			BS	412		-
			2 PzS	501		
2.2	Load per laden axle, drive side/load side (±10%), load = 2000 kg	kg		672/1340	718/1494	858/1643
2.3	Load per unladen axle, drive side/load side (±10%)	kg		317/95		390/111

WHEELS				EXH16	EXH18	EXH20 / EXH20+
3.1	Tyre: polyurethane, rubber, drive side/load side			Polyurethane		
3.2	Drive wheel dimensions (width at the ground)	Ø x W (mm)		Ø230 x l75		
3.3	Dimensions of wheels, load side <sup>(4)</sup>	Ø x W (mm)		Ø85 x W85 (bogies: Ø85 x W80)		
3.4	Additional wheels (dimensions)	Ø x W (mm)		2 x Ø125 x W40		
3.5	Number of wheels at drive side/load side (x = drive wheel) <sup>(4)</sup>			1X + 2/2 (1X + 2/4)		
3.6	Track width, drive side (±5 mm)	mm		482		
3.7	Track width, load side (±5 mm)	mm	52/54/56/68	355/375/395/515		

## Datasheet for EXH16, EXH18, EXH20 and EXH20+ models

DIMENSIONS				EXH16	EXH18	EXH20 / EXH20 +
4.4	Lift ( $\pm 5$ mm)	h3 (mm)		125		
4.9	Height of tiller in driving position minimum/maximum ( $\pm 5$ mm)	h14 (mm)		810/1205		
4.15	Height at fork ends in the lowered position (0/+5 mm)	h13 (mm)		86		
4.19	Total length (+5 mm)	L1 (mm)	Compact	1579	-	-
			BS	1649		-
			2 PzS	1719		
4.20	Length to the load mating face ( $\pm 5$ mm)	L2 (mm)	Compact	429	-	-
			BS	499		-
			2 PzS	569		
4.21	Total width ( $\pm 5$ mm)	b1 (mm)		720		
4.22	Load arm dimensions	s/e/L (mm)		55/165/1150		
4.25	External clearance of the fork arms ( $\pm 5$ mm)	s/e/L (mm)		520/540/560/680		
4.32	Ground clearance, at the centre of the wheelbase ( $\pm 2$ mm) <sup>(5)</sup>	m2 (mm)		32		
4.33	Load dimension b12 x L6	b12 x L6		800 x 1200		
4.34	Aisle width with predetermined load <sup>(2)</sup> <sup>(3)</sup>	Ast (m m)	Compact	2069	-	-
			BS	2142		-
			2 PzS	2211		
4.34 .2	Aisle width with a pallet 800 x 1200 crosswise <sup>(3)</sup>	Ast (m m)	Compact	2165	-	-
			BS	2238		-
			2 PzS	2310		
4.35	Turning radius (minimum) Initial lift, raised/lowered <sup>(1)</sup>	Wa (mm)	Compact	1365/1 437	-	-
			BS	1438/1510		-
			2 PzS	1510/1582		

PERFORMANCE DATA			EXH16	EXH18	EXH20 / EXH20+
5.1	Travel speed, laden/unladen ( $\pm 5\%$ )	km/h	6 / 6		



Datasheet for EXH16, EXH18, EXH20 and EXH20+ models

5.2	Lifting speed, laden/unladen (±10%)	m/s	0.035/0.046	0.031/0.046	0.033/0.042
5.3	Lowering speed, laden/unladen (±10%)	m/s	0.07/0.028	0.073/0.028	0.069/0.035
5.8	Maximum gradient, laden/unladen	%	10/20	9/20	
5.9	Acceleration time (10 m), laden/unladen	s	7.1/6.6	6.9/6.4	7.1/6.4
5.10	Service brake		electromagnetic		

DRIVE SYSTEM					EXH16	EXH18	EXH20 / EXH20+
6.1	Traction motor, hourly output	kW			1.1	1.3	
6.2	Lift motor at 15% utilisation	kW			1		1.2
6.4	Battery voltage and capacity (discharge in 5 hours)	V/Ah	Gel/lead battery	Compact	24/62 or 125	-	-
				BS	24/150		-
				2 PzS	24/250		
6.5	Battery weight (±10%)	(kg)	Gel/lead battery	Compact	22	-	-
				BS	140		-
				2 PzS	210		
6.6	Energy consumption according to standardised VDI cycle	kWh/h			0.272	0.259	0.3
6.62	CO2 equivalent emission for electricity grid energy	kg/h			0.147	0.14	0.162
6.7	Turnover output	T/h			88	101	110
6.8	Energy consumption at turnover output	kWh/h			148	163	176

MISCELLANEOUS				EXH16	EXH18	EXH20 / EXH20+
8.1	Speed monitor (AC controller)			KWPC		
10.7	Noise level at forklift operator's ears (±2.5)	dB (A)		63		

1) Forks raised/lowered

2)  $A_{st} = W_a + R + \text{Safety distance } a$   
 $a=200 \text{ mm}$

3) With Creep Speed option. Tiller in vertical position.

## Eco-design requirements for electric motors and variable speed drives

- 4) With bogies in brackets
- 5) Minimum/maximum

### Eco-design requirements for electric motors and variable speed drives

All motors in this industrial truck are exempt from Regulation (EU) 2019/1781 because these motors do not meet the description given in Article 2 "Scope", Item (1) (a) and because of the provisions in Article 2 (2) (h) "Motors in cordless or battery-operated equipment" and Article 2 (2) (o) "Motors designed specifically for the traction of electric vehicles".

All variable speed drives in this industrial truck are exempt from Regulation (EU) 2019/1781 because these variable speed drives do not meet the description given in Article 2 "Scope", Item (1) (b).

**A**

Address of manufacturer. ....	1
Aerosol can for chains. ....	103
Anti-crush safety device	
Checking. ....	43
Job description. ....	42

**B**

Basic display operating unit. ....	32
Batteries	
General information on changing batteries. ....	86
Battery	
Charging the battery using an external charger. ....	82
Type. ....	78
Battery acid. ....	18
Battery indicator. ....	45
Before leaving the truck. ....	77
Before picking up a load. ....	73
Brake	
Checking the brake. ....	41
Braking. ....	36, 53
Braking by releasing the drive switch. ....	54
Braking by reversing the drive direction. ....	54

**C**

Changing the battery on a truck equipped with a side-access battery. ....	88
Changing the vertical access battery. ....	86
Charging the battery. ....	107
Checking the anti-crush safety device. ....	42
Checking the battery acid level and electrolyte density. ....	112
Checking the cables, terminals and the battery connector. ....	113
Checking the condition of the load arms. ....	108
Checking the emergency off. ....	41
Checking the horn. ....	42
Checks prior to start-up. ....	38
Choice of opening side for battery compartment. ....	91
Cleaning the truck. ....	106
Climatic conditions. ....	12
Closing the battery hood. ....	79
cold store. ....	75
Cold store usage. ....	75

Conformity marking. ....	3
Connecting the battery connector. ....	80
Consumables. ....	17
Battery acid safety instructions. ....	18
Disposal. ....	19
Oil Safety Information. ....	17
Safety information for handling hydraulic fluid. ....	18
Contact details. ....	1
Copyright and property rights. ....	2

**D**

Datasheet for EXH16, EXH18, EXH20 and EXH20+ models. ....	124
Datasheet for the EXH14 model. ....	120
Declaration of conformity. ....	4
Defining directions. ....	51
Description of use. ....	12
Destruction. ....	117
Different performance modes. ....	46
Disconnecting the battery connector. ....	80
Disposing of components and batteries. ....	13
Double throw safety switch. ....	55
Drive direction. ....	59
Driver rights, duties and rules of behaviour. ....	22
Drivers. ....	22
Driver's compartment. ....	37
Drive system. ....	36
Driving. ....	51, 59
Driving on loading bridges. ....	95
Driving safety guidelines. ....	50

**E**

Easily accessing the technical compartment. ....	101
EC declaration of conformity in accordance with the Machinery Directive. ....	4
Electrical equipment	
Cleaning and blowing air through the components. ....	111
Electromagnetic braking. ....	53
Electronic key (option). ....	30
Emergency off switch. ....	55

**F**

Features. ....	36
----------------	----

<b>FleetManager™</b>	
Colour code for the LEDs. . . . .	66
Commissioning a truck equipped with a keypad or an electronic key. . . . .	65
Commissioning a truck equipped with an RFID reading device. . . . .	65
Description. . . . .	64
Disconnecting a truck equipped with a keypad or electronic key. . . . .	68
Disconnecting a truck equipped with an RFID reading device. . . . .	69
Disconnecting the truck. . . . .	68
Start-up. . . . .	65
<b>G</b>	
General. . . . .	2, 98
General information on battery maintenance. . . . .	107
General view of EXH-SF 16C and EXH-SF 20C trucks. . . . .	28
General view of EXH 14, EXH 16, EXH 18, EXH 20 and EXH 20+ trucks. . . . .	26
Grade and quantity of lubricants and other consumables. . . . .	98
<b>H</b>	
Horn. . . . .	54
Hydraulic fluid. . . . .	18
Hydraulic system	
Checking the hydraulic oil level. . . . .	114
Checking the hydraulic system for leaks. . . . .	114
<b>I</b>	
Identification label. . . . .	6
<b>L</b>	
Labels. . . . .	33
Lifting and lowering the load arms. . . . .	72
Lifting the truck. . . . .	94
List of abbreviations. . . . .	7
Load handling. . . . .	72
Load handling safety rules. . . . .	70
<b>M</b>	
Maintenance plan. . . . .	98
Multi-purpose grease. . . . .	103
<b>N</b>	
Noise emission values. . . . .	20
<b>O</b>	
Oils. . . . .	17
On-board charger	
Adjusting the on-board charger. . . . .	85
Using the on-board charger. . . . .	84
Opening the battery hood. . . . .	79
Operating company. . . . .	22
Ordering spare parts and consumables. . . . .	99
Order picking. . . . .	78
Other display icons. . . . .	47
<b>P</b>	
Pedestrian driving. . . . .	61
Permanent Putting Out of Commission. . . . .	117
Permissible use. . . . .	12
Picking up a load from the ground. . . . .	73
Precautions to be taken during battery maintenance. . . . .	107
Prohibition of use by unauthorised persons. . . . .	23
<b>R</b>	
Recommended lubricants. . . . .	103
Refitting the battery. . . . .	86
Removing the battery. . . . .	86
Residual dangers, residual risks. . . . .	21
Ride-on driving. . . . .	62
<b>S</b>	
Safety devices. . . . .	100
Safety Inspection. . . . .	24
Serial number. . . . .	34
Service plan	
1000 hours. . . . .	104
10,000 hours. . . . .	105
3000 hours. . . . .	105
Servicing and maintenance measures. . . . .	100
Setting a load down on the ground. . . . .	74
Slinging the truck. . . . .	93
Spare parts list. . . . .	10
Specialist. . . . .	22
Stabiliser maintenance. . . . .	110
Stabilisers. . . . .	37
Stability. . . . .	21
Starting on a ramp. . . . .	57
Starting up. . . . .	39

Steering. ....	36, 52, 60	Truck operating instructions. ....	44
Symbols used. ....	13	<b>U</b>	
<b>T</b>		Unauthorised use. ....	13
Technical data for inspection and maintenance. ....	102	Using the side socket to charge the lithium-ion battery. ....	81
Technical description. ....	36	Using the truck on a ramp. ....	56
Tortoise button. ....	56	<b>V</b>	
Towing and transporting the truck. ....	92	Vibrations	
Towing the truck. ....	92	Vibration characteristics for vibrations to which the body is exposed. ....	20
Traction motor		View of the technical compartment. ....	27
Cleaning the traction motor cooling fins. ....	109	<b>W</b>	
Transporting a load. ....	74	Warnings on the display. ....	48
Transporting the machine. ....	92, 95	Wheels	
Transporting the truck. ....	94	Checking the condition of the wheels. ....	110
Transporting the truck in the lift. ....	95	Working on the electrical equipment. ....	100
Travelling down slopes. ....	57		
Travelling up slopes. ....	57		
Truck controls. ....	29		





STILL GmbH

11558011551 EN - 04/2023 - 03